

EON515

Portable Self-Powered 15", Two-Way, Bass-Reflex Design

Professional Series

Applications:

- ▶ Live sound reinforcement, speech and vocals, music playback in entertainment, A/V, and institutional venues – especially when ease of use and portability are important factors.
- ▶ Amplification, mixing, and monitoring for electronic musical instruments.
- ▶ Everywhere you need to be heard.

Features:

- ▶ 450 watt High-Performance Powered Speaker System
- ▶ True portability weighing only 14.8 kg (32.5 lb)
- ▶ Multiple handles with comfort rubber grips for easy transport
- ▶ 15" Differential Drive® low-frequency driver with neodymium magnet for low-distortion and light weight
- ▶ 1" throat diameter next generation JBL neodymium compression driver
- ▶ Efficient Crown® Class-D amplifier technology
- ▶ Built-in 3 Channel Mixer
- ▶ 100° H x 60° V asymmetrical wave guide for uniform audience coverage
- ▶ Line level and direct microphone input capability
- ▶ Selectable Pre-engineered EQ settings
- ▶ Unique Mix/Loop signal flow function for extended system application
- ▶ Easy "daisy-chain" connections for extending the system
- ▶ Integrated M10 suspension points for easy rigging
- ▶ Multi angle enclosure for main or monitor applications
- ▶ Integrated 36 mm pole mount socket with stabilizing securing screw
- ▶ Highly designed composite enclosures for durability, lightweight, and acoustic performance

The EON515 is a 15-inch, two-way, powered, portable speaker system. Capable of reproducing full bandwidth sound at high levels it offers the additional utility of a 3 channel built-in mixer. The EON515 is comprised of a 380 mm (15 in) Differential Drive® woofer, a 25.4 mm (1 in) neodymium high frequency compression driver coupled to a 100° H by 60° V waveguide. Both components are driven by the discrete channels of a 450 watt Crown® Class-D integrated power amplifier. The input section contains all crossover functions, protection, and mixer functionality.

The mixer offers XLR or ¼-inch TRS phone jack compatibility. Selectable input sensitivities allow a broad range of devices to be properly matched. A unique mix/loop signal flow router provides opportunities for daisy chaining or rigging with the built-in mixer only. Pre-engineered system EQs allow for matching the settings to the actual source material. In the "cut" position maximum level can be achieved for speech reproduction by reducing need to reinforce the lower frequencies. This is also a typical setting when using the system as a floor monitor, reducing low frequency build-up which occurs naturally when placed on a floor. The "flat" setting is ideal for live music and the "boost" for reproducing low level pre-recorded music, delivering extra low and high frequency energy. The signal present and limit lights indicate performance status. An additional switch is provided to defeat the illuminated logo in theatre applications.



In addition to acoustic performance the EON515 features three full size deep-well handles, light weight, and balanced ergonomics. The new generation of EON products offers true portability and ease of handling. Five standard M10 rigging points and integrated pole mount socket increase the system's utility. The extremely rugged copolymer enclosure has been designed for main and 45° monitor orientation in the left and right hand configuration. A full screen-backed steel grille offers additional protection for both the woofer and compression driver components.

Specifications:

System Type:	Self powered 15", two-way, bass-reflex design
Frequency Range (-10 dB):	39 Hz -20 kHz (EQ in 'Flat' position)
Frequency Response (±3 dB):	42 Hz - 18 kHz (EQ in 'Flat' position)
Coverage Pattern:	100° H x 60° V nominal
Directivity Index (DI):	9 dB
Directivity Factor (Q):	8
Crossover Frequency:	2.2 kHz
System Power Rating:	450 W continuous, 900 W peak
LF Power amp:	350 W continuous at driver impedance
HF Power amp:	100 W continuous at driver impedance
Distortion:	Less than 0.1% at rated power
Maximum SPL:	129 dB
Signal indicators:	Limit: Red LED indicates input overload condition Signal: Green LED indicates signal present Mic/Line: Red LED indicator
Input Gain (input 3):	Mic position: -Infinity to +40 dB Line position: -Infinity to +4 dB (+20 dBu Max signal input)
Input Gain (input 1 & 2):	-Infinity to +4 dB (+20 dBu Max signal input)
Input Impedance:	64 K Ohms (balanced), 32 K Ohms (unbalanced)
Boost EQ:	LF +3 dB Shelving Filter @ 200 Hz HF +2.5 dB Shelving Filter @ 4 kHz
Low Cut Filter:	Preset high pass @ 120 Hz
LF Driver:	1 x JBL 265F-1 380 mm (15 in) Differential Drive® integrated woofer with dual 2" voice coils
HF Driver:	1 x JBL 2414H 25.4 mm (1 in) neodymium compression driver
Input 3 connector:	Balanced XLR / ¼ inch TRS combo jack with XLR loop through
Input 1 & 2 connectors:	Balanced ¼ inch TRS jack
Output (Loop/Mix switch):	Balanced male XLR, +20 dBu (peak) o/p level in MIX position
XLR Pin Assignments:	Pin 2 (+), Pin 3 (-), Pin 1 (GND)
Limiting/Protection:	Dynamic Limiter
Enclosure:	PP impact copolymer, multi-purpose main & monitor orientation.
Handles:	One left/right side, one on top, with rubber grip
Suspension / Mounting:	36 mm pole socket with stabilizing screw, 4 x M10 suspension points, 1 x M10 pull-back point
Grille:	Powder coated perforated steel with acoustically transparent black screen backing.
AC input:	120 – 240 V, 50/60 Hz
Dimensions (H x W x D):	685 x 438 x 366 mm (27.0 in x 17.3 in x 14.4 in)
Net Weight:	14.8 kg (32.5 lb)

JBL continually engages in research related to product improvement. Some materials, production methods and design refinements are introduced into existing products without notice as a routine expression of that philosophy. For this reason, any current JBL product may differ in some respect from its published description, but will always equal or exceed the original design specifications unless otherwise stated.

▶ EON515 Portable Self-Powered 15", Two-Way, Bass-Reflex Design

On Axis Frequency Response

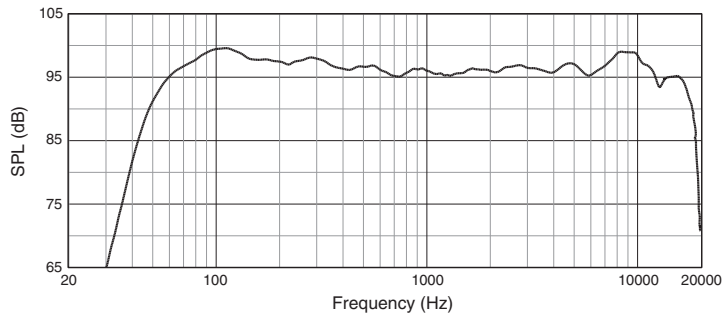

Block Diagram

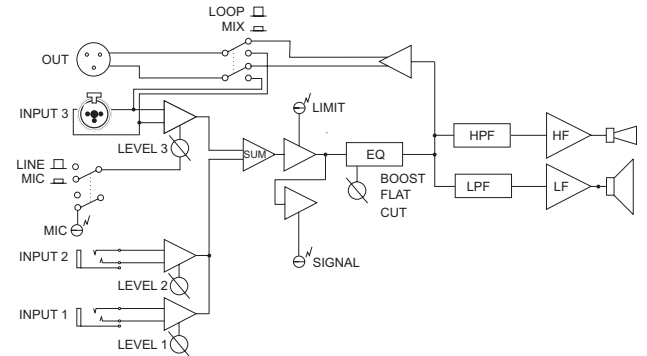

Input Panel

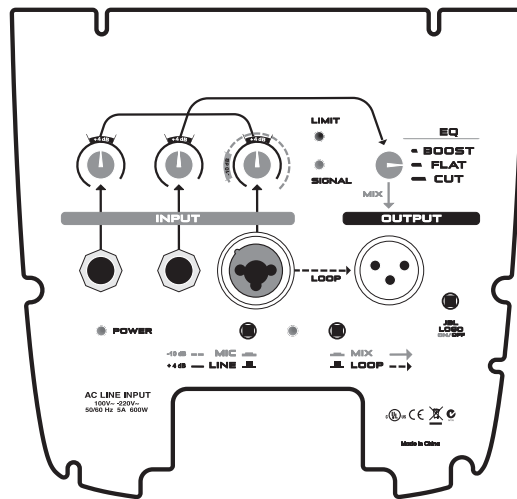

Dimensions

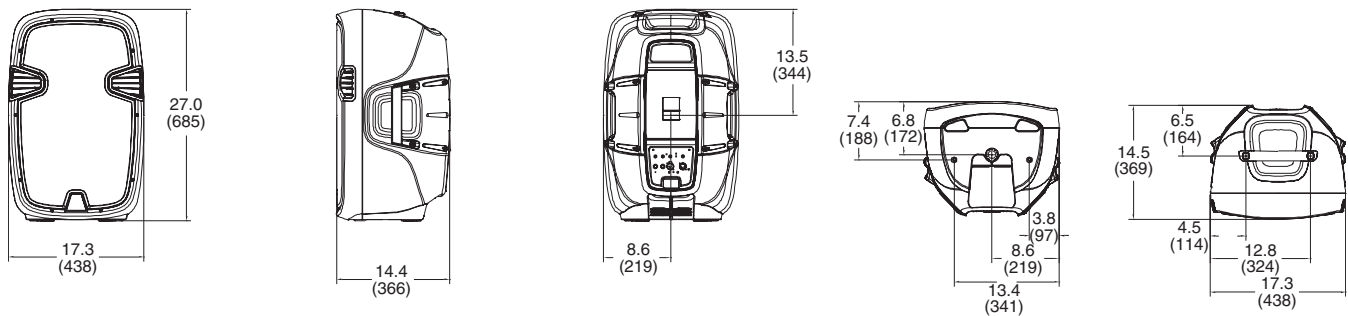

Dimensions in inches (in)



JBL Professional
8500 Balboa Boulevard, P.O. Box 2200
Northridge, California 91329 U.S.A.

A Harman International Company
© Copyright 2008 JBL Professional
www.jblpro.com

SSEON515
CRP 5M
09/08