

COLORstrip™ Mini

Snapshot

| | |
|---------------------------|---|
| Use on Dimmer | ⊘ |
| Outdoor Use | ⊘ |
| Sound Activated | ✓ |
| DMX | ✓ |
| Master/Slave | ✓ |
| Auto-ranging Power Supply | ✓ |
| Replaceable Fuse | ✓ |
| User Serviceable | ⊘ |
| Duty Cycle | ⊘ |

User Manual



Value · Innovation · Performance

5200 NW 108th Ave, Sunrise, FL 33351 U.S.A.

(800) 762-1084 – (954) 929-1115

FAX (954) 929-5560

www.chauvetlighting.com



TABLE OF CONTENTS

| | |
|--|-----------|
| 1. BEFORE YOU BEGIN | 3 |
| WHAT IS INCLUDED..... | 3 |
| UNPACKING INSTRUCTIONS..... | 3 |
| MANUAL CONVENTIONS..... | 3 |
| ICONS..... | 3 |
| SAFETY INSTRUCTIONS..... | 4 |
| 2. INTRODUCTION | 5 |
| FEATURES..... | 5 |
| <i>Additional Features</i> | 5 |
| <i>Optional Controller</i> | 5 |
| DMX CHANNEL SUMMARY..... | 5 |
| PRODUCT OVERVIEW..... | 6 |
| 3. SETUP | 7 |
| AC POWER..... | 7 |
| <i>Power Linking</i> | 7 |
| MOUNTING..... | 8 |
| <i>Orientation</i> | 8 |
| <i>Rigging</i> | 8 |
| 4. OPERATING INSTRUCTIONS | 9 |
| CONFIGURING THE STARTING ADDRESS..... | 10 |
| <i>DMX Operation</i> | 10 |
| <i>Master/Slave Mode (Sound-Active, Auto Mode)</i> | 10 |
| <i>Master/Slave Linking</i> | 11 |
| <i>DMX Linking</i> | 11 |
| <i>Automatic</i> | 12 |
| <i>Sound-Active</i> | 12 |
| <i>Static Colors</i> | 12 |
| <i>Custom Colors</i> | 13 |
| DMX CHANNEL VALUES..... | 13 |
| 5. APPENDIX | 14 |
| DMX PRIMER..... | 14 |
| GENERAL TROUBLESHOOTING..... | 14 |
| FIXTURE LINKING..... | 15 |
| DATA CABLING..... | 15 |
| <i>DMX Data Cable</i> | 15 |
| CABLE CONNECTORS..... | 16 |
| SETTING THE STARTING ADDRESS..... | 16 |
| <i>3-Pin to 5-Pin Conversion Chart</i> | 17 |
| <i>Setting up a DMX Serial Data Link</i> | 17 |
| GENERAL MAINTENANCE..... | 18 |
| RETURNS PROCEDURE..... | 18 |
| CLAIMS..... | 18 |
| TECHNICAL SPECIFICATIONS | 19 |
| CONTACT US | 20 |

1. BEFORE YOU BEGIN

What is included

- 1 x COLORstrip™ Mini
- 1 x Mounting kit (short)
- 1 x Mounting kit (long)
- 1 x Power Cord
- 1 x Warranty Card
- 1 x User Manual

Unpacking Instructions

Immediately upon receiving a fixture, carefully unpack the carton, check the contents to ensure that all parts are present, and have been received in good condition. Notify the shipper immediately and retain packing material for inspection if any parts appear damaged from shipping or the carton itself shows signs of mishandling. Save the carton and all packing materials. In the event that a fixture must be returned to the factory, it is important that the fixture be returned in the original factory box and packing.



Manual Conventions

CHAUVET® manuals use the following conventions to differentiate certain types of information from the regular text.

| CONVENTION | MEANING |
|---------------------------|---|
| [10] | A DIP switch to be configured |
| <Menu> | A key to be pressed on the fixture's control panel |
| 1~512 | A range of values |
| 50/60 | A set of values of which only one can be chosen |
| <i>Settings</i> | A menu option not to be modified (for example, showing the operating mode/current status) |
| <i>MENU > Settings</i> | A sequence of menu options to be followed |
| ON | A value to be entered or selected |

Icons

This manual uses the following icons to indicate information that requires special attention on the part of the user.

| ICONS | MEANING |
|---|---|
|  | This paragraph contains critical installation, configuration or operation information. Failure to comply with this information may render the fixture partially or completely inoperative, cause damage to the fixture or cause harm to the user. |
|  | This paragraph contains important installation or configuration information. Failure to comply with this information may prevent the fixture from functioning correctly. |
|  | This paragraph reminds you of useful, although not critical, information. |

Safety Instructions



Please read these instructions carefully. It includes important information about the installation, usage and maintenance of this product.

- Please keep this User Manual for future consultation. If you sell the unit to another user, be sure that they also receive this instruction booklet.
- Always make sure that you are connecting to the proper voltage, and that the line voltage you are connecting to is not higher than that stated on the decal or rear panel of the fixture.
- This product is intended for indoor use only! To prevent risk of fire or shock, do not expose fixture to rain or moisture.
- Make sure there are no flammable materials close to the unit while operating.
- The unit must be installed in a location with adequate ventilation, at least 20 in (50 cm) from adjacent surfaces. Be sure that no ventilation slots are blocked.
- Always disconnect from power source before servicing or replacing fuse and be sure to replace with same fuse source.
- Secure fixture to fastening device using a safety chain.
- Maximum ambient temperature (Ta) is 104° F (40° C). Do not operate fixture at temperatures higher than this.
- In the event of a serious operating problem, stop using the unit immediately. Never try to repair the unit by yourself. Repairs carried out by unskilled people can lead to damage or malfunction. Please contact the nearest authorized technical assistance center.
- Never connect the device to a dimmer pack.
- Make sure the power cord is never crimped or damaged.
- Never disconnect the power cord by pulling or tugging on the cord.
- Never carry the fixture directly from the cord. Always use the hanging/mounting bracket.
- Avoid direct eye exposure to the light source while it is on.

2. INTRODUCTION

Features

- 4-channel DMX-512 LED linear wash light
- Blackout/static/dimmer/strobe
- Static colors and RGB color mixing with or without DMX controller
- Built-in automated programs via master/slave or DMX
- Built-in sound activated programs via master/slave or DMX

Additional Features

- Compatible with CHAUVET® Satellite™ system
- Additional power output: max 20 units
- Additional slave output allows for color-changing runway effect (up to 31 units)

Optional Controller

- Foot Controller (LED-FS1)

DMX Channel Summary

| Static Colors w/Strobe | | Chase Programs | | RGB Dimming | | Color Fade | |
|------------------------|-----------------------------------|----------------|---------------------------------|-------------|------------------------------------|------------|-------------------------------------|
| 1 | DMX: (000-079) Color Selection | 1 | DMX: (080-209) Programs 1~13 | 1 | DMX: (210-219) RGB Color Mixing | 1 | DMX: (220-255) Color Fade & Auto |
| 2 | No Function | 2 | Run Speed (0~100%) | 2 | Red | 2 | Fade/Run Speed (0~100%) |
| 3 | Strobe (0~100%) | 3 | Strobe (0~100%) | 3 | Green | 3 | No Function |
| 4 | No Function | 4 | No Function | 4 | Blue | 4 | No Function |

Product Overview

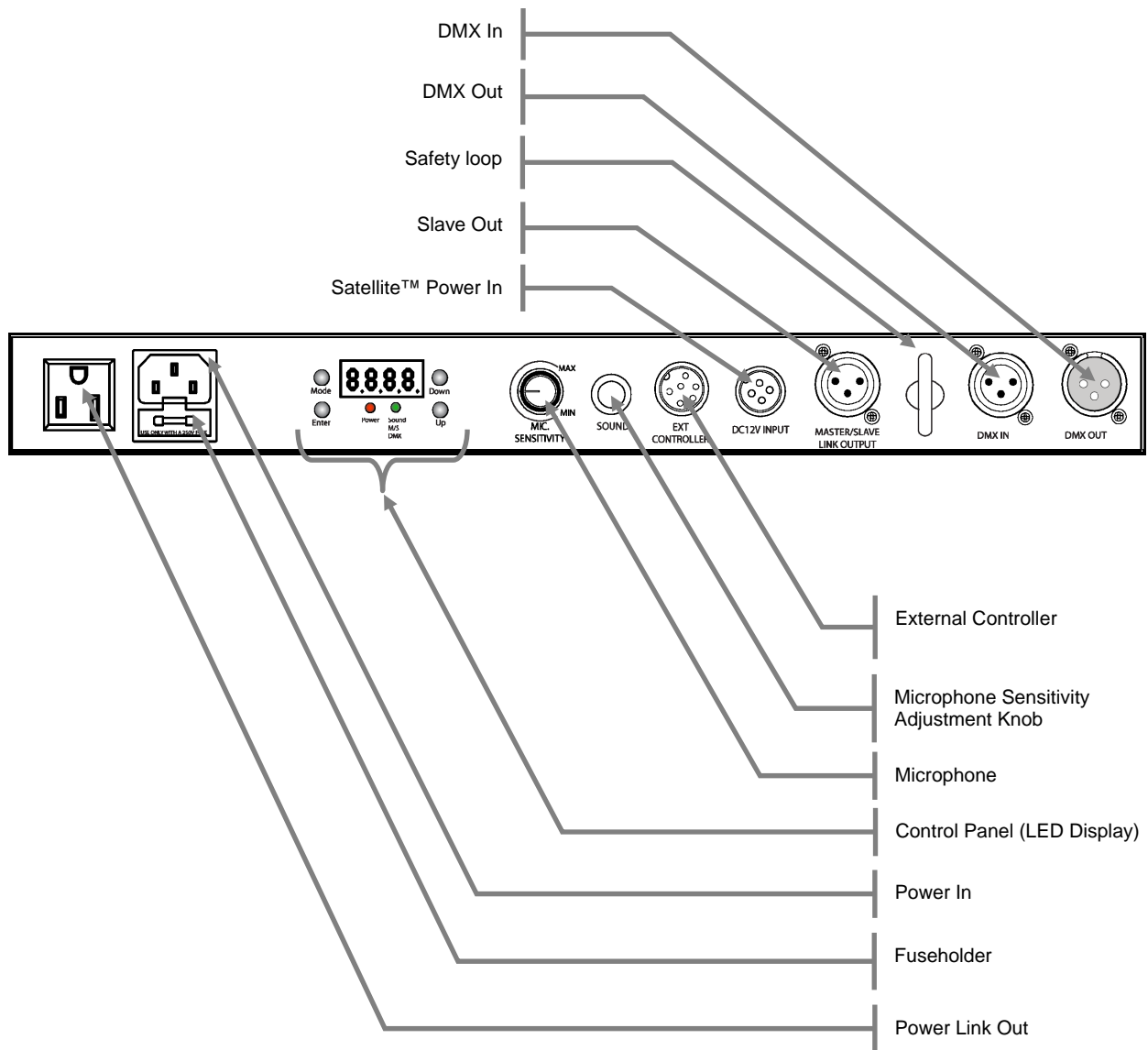

3. SETUP

AC Power

This fixture runs on 100~240 VAC, 50/60 Hz. Before powering on the unit, make sure the line voltage to which you are connecting it is within the range of accepted voltages.

To determine the power requirements for a particular fixture, see the label affixed to the back plate of the fixture or refer to the fixture's specifications chart. A fixture's listed current rating indicates its average current draw under normal conditions.



Always connect the fixture to a switched circuit. Never connect the fixture to a rheostat (variable resistor) or dimmer circuit, even if the rheostat or dimmer channel is used only as a 0 to 100% switch.



Always connect the fixture to a circuit with a suitable electrical ground.

Power Linking

This fixture contains power linking via the IEC outlet located next to the power input IEC. Please see the diagram below for further explanation.



The maximum quantity of fixtures that may be linked is 15.

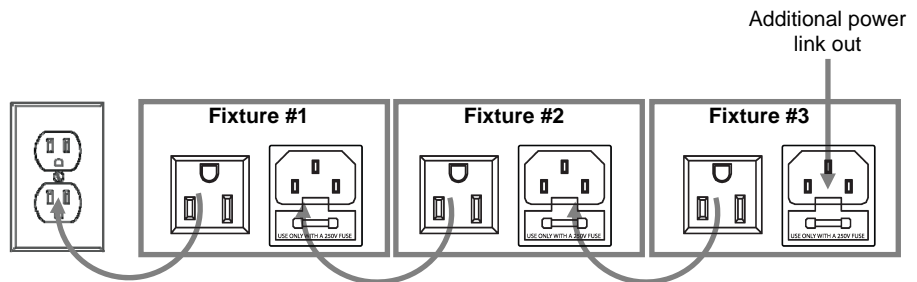
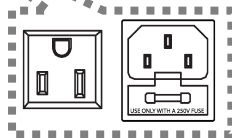
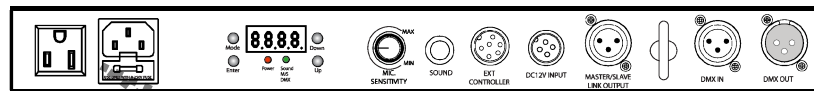

The power linking shown in this document is for the Chauvet® North American version ONLY! Therefore, it is the customer's responsibility to check with the Dealer/Distributor regarding power linking on the local version of the product. Connections and availability may change, depending on the power requirements and/or regulations of each country/region.

Mounting

Orientation

The COLORstrip™ Mini may be mounted in any safe position provided there is adequate room for ventilation.

Rigging

Be sure that the structure can support the weight of the fixture. Please see the "Technical Specifications" section of this manual for a detailed weight listing. Mount the fixture securely. This may be done with a screw, nut and bolt, or a hanging clamp. The hole in each bracket is 13 mm in size. When rigging consider routine maintenance and control panel access. Please see the following steps for installation.

- If the power link out is intended to be used with multiple fixture, take into account the length of each power cable, and mount the fixtures close enough to one another to accommodate for this.
- When aiming the fixtures, you may use the bracket adjustment knob. Loosen the knob, adjust to the desired angle, and then tighten the knob by turning clockwise. Do not use tools for this step, as it may cause damage.
- There is a secondary portion of the bracket, which may be used primarily for floor standing positions.
- Safety cables must always be used.



4. OPERATING INSTRUCTIONS

| BUTTON | FUNCTION |
|---------|--|
| <Mode> | Used to activate Mode selection and to back out of the current Function 1 or 2. |
| <Enter> | Used to select a value and store it to memory |
| <Up> | Used to select increasing advancement in the value |
| <Down> | Used to select decreasing advancement in the value |

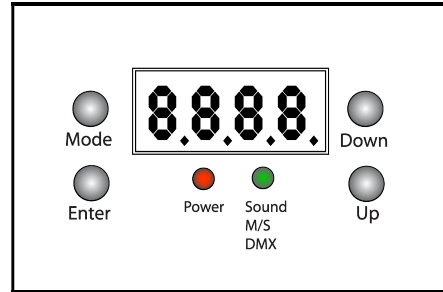

The Control Panel shows the current state of the unit. It is used to select the operating mode, as well as the sub-features. For a detailed layout of the control panel functions, please see the “menu map” section below.

| Mode | Function 1 | Function 2 | Description | Run Speed (P) | Strobe Speed (F) | (C) | | |
|------|--------------------------------|------------|---------------------------------|-----------------|-------------------------|----------------|---------------|--|
| ACt | A000 | 000 | <i>Blackout</i> | | | | | |
| | | 001 | <i>Red</i> | | 000~100 | | | |
| | | 002 | <i>Green</i> | | 000~100 | | | |
| | | 003 | <i>Blue</i> | | 000~100 | | | |
| | | 004 | <i>Yellow</i> | | 000~100 | | | |
| | | 005 | <i>Purple</i> | | 000~100 | | | |
| | | 006 | <i>Cyan</i> | | 000~100 | | | |
| | | 007 | <i>White</i> | | 000~100 | | | |
| | | 008 | <i>Color change 1</i> | Auto 000~050 | | 000~100 | | |
| | | 009 | <i>Color change 2</i> | | | 000~100 | | |
| | | 010 | <i>Color change 3</i> | | | 000~100 | | |
| | | 011 | <i>Color change 4</i> | | | 000~100 | | |
| | | 012 | <i>Color change 5</i> | | | 000~100 | | |
| | | 013 | <i>Color change 6</i> | | | | | |
| | | 014 | <i>Sequential color Chase 1</i> | | Sound-Active 051~100 | | | |
| | | 015 | <i>Sequential color Chase 2</i> | | | | | |
| | | 016 | <i>Sequential color Chase 3</i> | | | | | |
| | | 017 | <i>Sequential color Chase 4</i> | | | | | |
| | | 018 | <i>Sequential color Chase 5</i> | | | | | |
| | | 019 | <i>Sequential color Chase 6</i> | | | | | |
| | | 020 | <i>Sequential color Chase 7</i> | | | | | |
| | | 021 | <i>RGB</i> | | Red: 000~100 | Green: 000~100 | Blue: 000~100 | |
| | | 022 | <i>Color fade</i> | 000~100 | | | | |
| 023 | <i>Sound-Active (Auto Run)</i> | | | | | | | |
| SYS | SdAd | | <i>DMX Address</i> | 001~509 | | | | |
| | AAAd | | <i>Reset</i> | | | | | |

Configuring the Starting Address

Each fixture requires a starting address from 1–512. A fixture requiring one or more channels for control begins to read the data on the channel indicated by the starting address. For example, a fixture that uses seven DMX channels and is addressed to start on DMX channel 100, will read data from channels: 100, 101, 102, 103, 104, 105 and 106. Choose the starting addresses for each fixture so that the channels used do not overlap. In addition, you should note the starting address selected for future reference.

The COLORstrip™ Mini fixture uses four DMX channels. If this is your first time using DMX, we recommend reading the “DMX Primer” section in the “Appendix”.

DMX Operation

This is the operating mode which will allow for control with an external DMX controller. You must set the starting address for this mode. If this is your first time using DMX, then it is recommended that you refer to the “DMX Primer” section in the “Appendix” of this manual.

1. Press **<Mode>** until *Act* or *SYS* appears on the LED screen.
2. Using **<Up>** & **<Down>**, select *SYS*.
3. Press **<Enter>**.
4. Using **<UP>** and **<DOWN>**, select the *SdAd*.
5. Press **<Enter>**.
6. Using **<UP>** and **<DOWN>**, select the DMX starting address **001-509**.
7. Press **<Enter>**.

Master/Slave Mode (Sound-Active, Auto Mode)

This is the operating mode which will allow one fixture to act as the “master” and control all of the other “slave” fixtures. You must link the fixtures together using DMX cables.

1. Connect the master/slave out of the first fixture to the DMX in of the first slave fixture.
2. The slave fixture will automatically change to the slave mode. The display will read “L05”. Each unit will have an ascending number, increasing by 4. This is automatically set.
3. Plug the third unit into the master/slave out of the first slave. The display will read “L09”.
4. Set the master unit to either **Sound-Active** or **Auto Mode**.
5. Once all the slave fixtures have been connected and powered, activate **SYS>SAAd** on from the control panel to confirm that all the slave fixtures have been properly recognized.



Only one fixture may be set to master.



Do not connect a DMX controller to the daisy chain for this operating mode.



It does not matter which DMX mode is selected for the slave fixtures. Either mode will be effective.

Master/Slave Linking

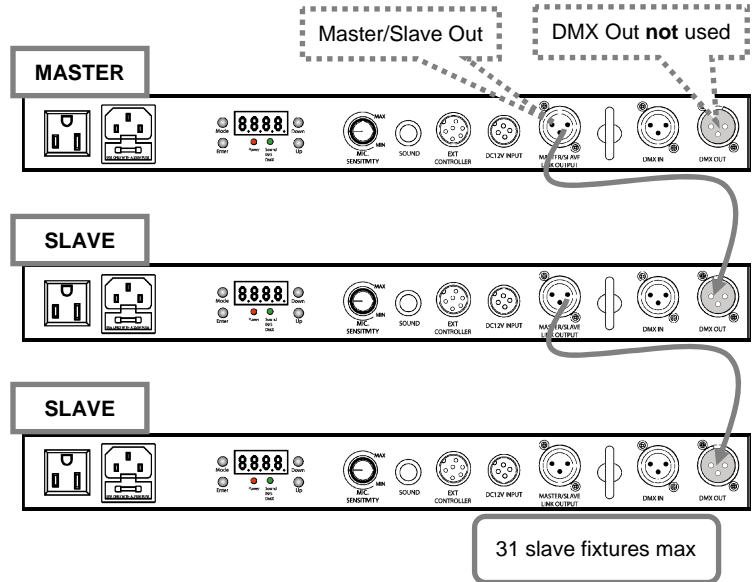

DMX Linking

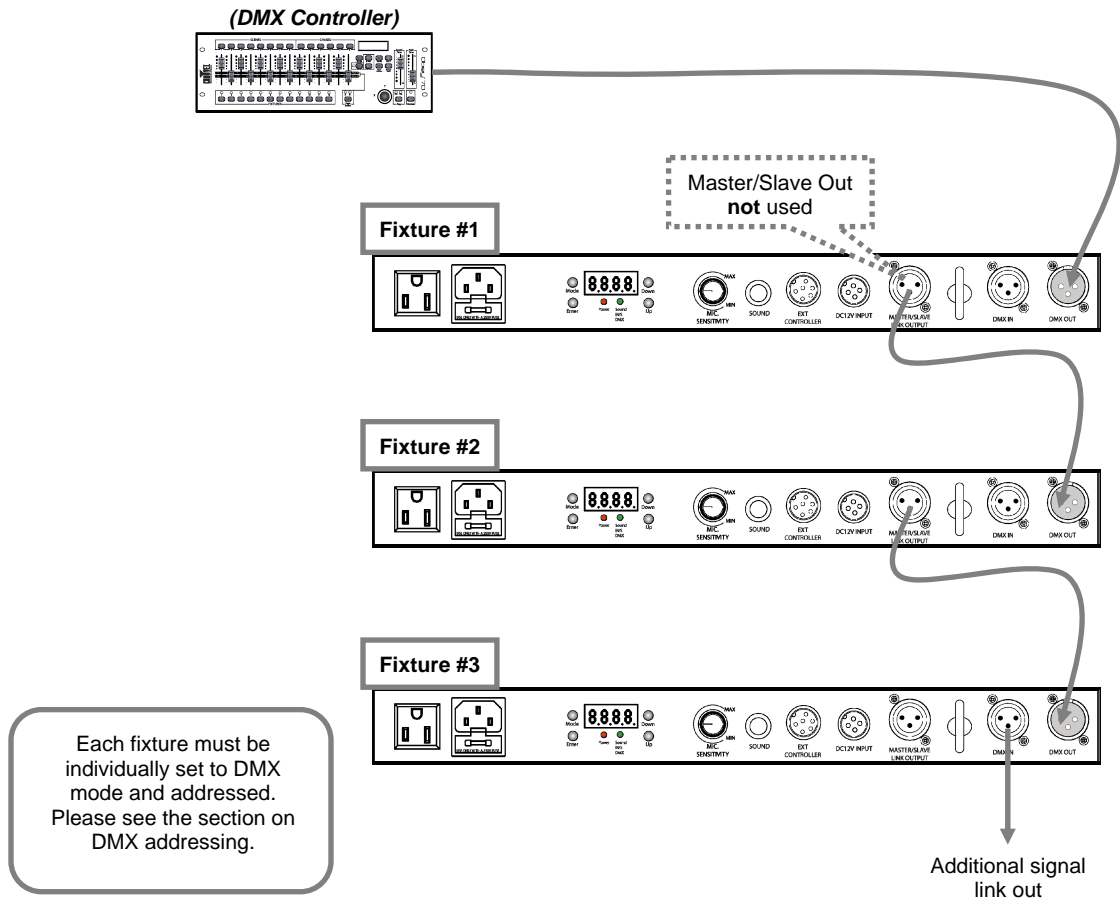

Automatic

This fixture has preprogrammed chases. These are accessed via the control panel. The speed may be adjusted for the chases. Please see the instructions below for further explanation.

1. Press **<Mode>** until **Act** or **SYS** appears on the LED screen.
2. Using **<Up>** & **<Down>**, select **Act**.
3. Press **<Enter>**.
4. Using **<UP>** and **<DOWN>**, select the desired program (**A008-020**).
5. Press **<Enter>** until **P_000~100** appears on the LED screen.
6. Using **<UP>** and **<DOWN>**, select the desired program speed (slow to fast) between **P001-050**.
7. Press **<Enter>**.
8. Press **<MENU>** until **P000~100** appears on the LED screen.
9. Press **<Enter>** until **F000~100** appears on the LED screen (**A008~011** only).
10. Using **<UP>** and **<DOWN>**, select the desired strobe speed.
11. Press **<Enter>**.



Strobe speed of 000 disables the function.

Sound-Active

This fixture has sound-active chases. These are accessed via the control panel. The microphone sensitivity may be adjusted using the microphone sensitivity adjustment knob. Please see the instructions below for further explanation.

8. Press **<Mode>** until **Act** or **SYS** appears on the LED screen.
9. Using **<Up>** & **<Down>**, select **Act**.
10. Press **<Enter>**.
11. Using **<UP>** and **<DOWN>**, select the desired program (**A008-020**).
12. Press **<Enter>** until **P000~100** appears on the LED screen.
13. Using **<UP>** and **<DOWN>**, select the run speed between **P 051-100** to set the fixture into sound-active mode.
14. Press **<Enter>**.
15. Press **<MENU>** until **P000~100** appears on the LED screen.
16. Press **<Enter>** until **F000~100** appears on the LED screen (**A008~011** only).
17. Using **<UP>** and **<DOWN>**, select the desired strobe speed.
18. Press **<Enter>**.



Strobe speed of 000 disables the function.

Static Colors

This fixture has sound-active chases. These are accessed via the control panel. The microphone sensitivity may be adjusted using the microphone sensitivity adjustment knob. Please see the instructions below for further explanation.

1. Press **<Mode>** until **Act** or **SYS** appears on the LED screen.
2. Using **<Up>** & **<Down>**, select **Act**.
3. Press **<Enter>**.
4. Using **<UP>** and **<DOWN>**, select the desired program (**A001-007**).
5. Press **<Enter>** until **F000~100** appears on the LED screen (**A008~011** only).
6. Using **<UP>** and **<DOWN>**, select the desired strobe speed.

Custom Colors

This fixture has sound-active chases. These are accessed via the control panel. The microphone sensitivity may be adjusted using the microphone sensitivity adjustment knob. Please see the instructions below for further explanation.

1. Press **<Mode>** until *Act* or *SYS* appears on the LED screen.
2. Using **<Up>** & **<Down>**, select **Act**.
3. Press **<Enter>**.
4. Using **<UP>** and **<DOWN>**, select **A021**.
5. Press **<Enter>** until **F000~100** appears on the LED screen.
6. Using **<UP>** and **<DOWN>**, select the desired intensity for the red LEDs.
7. Press **<Enter>** until **P000~100** appears on the LED screen.
8. Using **<UP>** and **<DOWN>**, select the desired intensity for the green LEDs.
9. Press **<Enter>** until **C000~100** appears on the LED screen.
10. Using **<UP>** and **<DOWN>**, select the desired intensity for the blue LEDs.
11. Press **<Enter>**.

DMX Channel Values

Channels 2, 3, and 4 will have different values, depending on the operating mode. The operating mode is controlled by channel 1. Please see the chart below that explains this concept.

| CHANNEL | VALUE | FUNCTION | CH 2 | CH 3 | CH 4 |
|-----------|--------------------------------|-------------------------|-----------------------------|-------------------------|-------------------------|
| 1 | | Static Colors | | | |
| | 000 ⇄ 009 | Blackout | | | |
| | 010 ⇄ 019 | Red | | | |
| | 020 ⇄ 029 | Green | | Strobe Speed 000~127 | |
| | 030 ⇄ 039 | Blue | | Sound-Active 250~255 | |
| | 040 ⇄ 049 | Yellow | | | |
| | 050 ⇄ 059 | Magenta | | | |
| | 060 ⇄ 069 | Cyan | | | |
| | 070 ⇄ 079 | White | | | |
| | | Color Changes | | | |
| | 080 ⇄ 089 | Color change 1 | | | Strobe Speed 000~127 |
| | 090 ⇄ 099 | Color change 2 | | | Sound-Active 250~255 |
| 100 ⇄ 109 | Color change 3 | | | | |
| 110 ⇄ 119 | Color change 4 | | | | |
| | Sequential Color Chases | | | | |
| 120 ⇄ 129 | Color change 5 | | | | |
| 130 ⇄ 139 | Color change 6 | | | | |
| | | | Run Speed | | |
| | | | Automatic 000~127 | | |
| | | | Sound-Active 128~255) | | |
| | | | | | |
| | 210 ⇄ 219 | RGB Color Mix | Red 0~100% | Green 0~100% | Blue 0~100% |
| | 220 ⇄ 015 | Color Fade | Fade Speed 0~100% | | |
| | 230 ⇄ 255 | Sound-Active (Auto Run) | | | |

5. APPENDIX

DMX Primer

There are 512 channels in a DMX connection. Channels may be assigned in any manner. A fixture capable of receiving DMX will require one or a number of sequential channels. The user must assign a starting address on the fixture that indicates the first channel reserved in the controller. There are many different types of DMX controllable fixtures and they all may vary in the total number of channels required. Choosing a start address should be planned in advance. Channels should never overlap. If they do, this will result in erratic operation of the fixtures whose starting address is set incorrectly. You can however, control multiple fixtures of the same type using the same starting address as long as the intended result is that of unison movement or operation. In other words, the fixtures will be slaved together and all respond exactly the same.

DMX fixtures are designed to receive data through a serial Daisy Chain. A Daisy Chain connection is where the DATA OUT of one fixture connects to the DATA IN of the next fixture. The order in which the fixtures are connected is not important and has no effect on how a controller communicates to each fixture. Use an order that provides for the easiest and most direct cabling. Connect fixtures using shielded two conductor twisted pair cable with three pin XLR male to female connectors. The shield connection is pin 1, while pin 2 is Data Negative (S-) and pin 3 is Data positive (S+).

General Troubleshooting

| SYMPTOM | POSSIBLE CAUSE(S) | POSSIBLE ACTION(S) |
|----------------------------------|--|--|
| Breaker/Fuse keeps blowing | <ul style="list-style-type: none"> Excessive circuit load Short circuit along the power wires | <ul style="list-style-type: none"> Check total load placed on the electrical circuit. Check for a short in the electrical wiring (internal and/or external). |
| Device does not power up | <ul style="list-style-type: none"> No power Loose power cord | <ul style="list-style-type: none"> Check for power on Mains. Check power cord |
| Fixture is not responding to DMX | <ul style="list-style-type: none"> Wrong DMX addressing Damaged DMX cables Wrong polarity settings on the controller Loose DMX cables Faulty DMX interface Faulty Main PCB | <ul style="list-style-type: none"> Check Control Panel and unit addressing Check DMX cables Check polarity switch settings on the controller Check cable connections Replace DMX input Replace Main PCB |
| Loss of signal | <ul style="list-style-type: none"> Non DMX cables Bouncing signals Long cable / Low level signal Too many fixtures Interference from AC wires | <ul style="list-style-type: none"> Use only DMX compatible cables Install terminator as suggested. Install amplifier right after fixture with strong signal. Install an optically coupled DMX splitter after unit #32. Keep DMX cables separated from power cables or black lights. |



If you still have a problem after trying the above solutions, please contact CHAUVET® Technical Support.

Fixture Linking

You will need a serial data link to run light shows of one or more fixtures using a DMX controller or to run synchronized shows on two or more fixtures set to a master/slave operating mode. The combined number of channels required by all the fixtures on a serial data link determines the number of fixtures the data link can support.



Fixtures on a serial data link must be daisy chained in one single line. To comply with the EIA-485 standard, no more than 32 fixtures should be connected on one data link. Connecting more than 32 fixtures on one serial data link without the use of a DMX optically-isolated splitter may result in deterioration of the digital DMX signal.

Maximum recommended serial data link distance: 500 m (1640 ft)

Maximum recommended number of fixtures on a serial data link: 32

Data Cabling

To link fixtures together you must obtain data cables. You can purchase CHAUVET® certified DMX cables directly from a dealer/distributor or construct your own cable. If you choose to create your own cable please use data-grade cables that can carry a high quality signal and are less prone to electromagnetic interference.

DMX Data Cable

Use a Belden© 9841 or equivalent cable which meets the specifications for EIA RS-485 applications. Standard microphone cables cannot transmit DMX data reliably over long distances. The cable must have the following characteristics:

| | |
|--|---|
| <i>Type:</i> | <i>shielded, 2-conductor twisted pair</i> |
| <i>Maximum capacitance between conductors:</i> | <i>30 pF/ft</i> |
| <i>Maximum capacitance between conductor and shield:</i> | <i>55 pF/ft</i> |
| <i>Maximum resistance:</i> | <i>20 ohms/1000 ft</i> |
| <i>Nominal impedance:</i> | <i>100 ~ 140 ohms</i> |

Cable Connectors

Cabling must have a male XLR connector on one end and a female XLR connector on the other end.

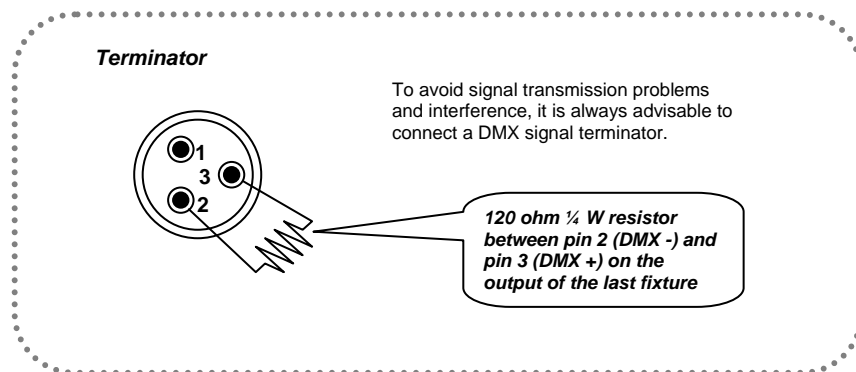
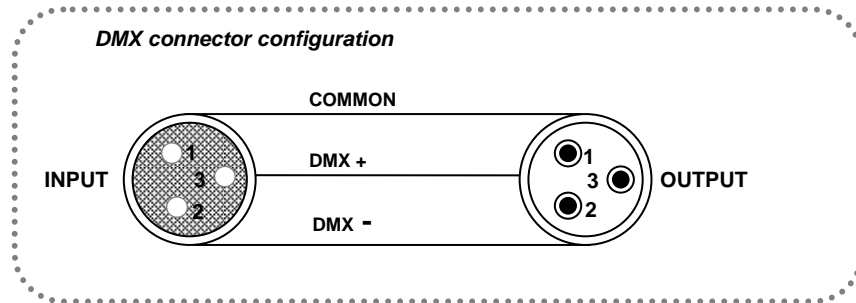

Do not allow contact between the common and the fixture's chassis ground. Grounding the common can cause a ground loop, and your fixture may perform erratically. Test cables with an ohm meter to verify correct polarity and to make sure the pins are not grounded or shorted to the shield or each other.

Setting the Starting Address

This DMX mode enables the use of a universal DMX controller device. Each fixture requires a start address from 1~512. A fixture requiring one or more channels for control begins to read the data on the channel indicated by the start address. For example, a fixture that uses six DMX channels and was addressed to start on DMX channel 100, would read data from channels: 100, 101, 102, 103, 104, and 105. Choose start addresses so that the channels used do not overlap, and note the start address selected for future reference.

If this is your first time addressing a fixture using the DMX control protocol, we suggest jumping to the "Appendix" section and reading the heading "DMX Primer". It contains very useful information that will help you understand its use.

3-Pin to 5-Pin Conversion Chart



If you use a controller with a 5-pin DMX output connector, you will need to use a 5-pin to 3-pin adapter. The chart below details a proper cable conversion:

| 3-PIN TO 5-PIN CONVERSION CHART | | |
|---------------------------------|-----------------------|--------------------|
| Conductor | 3-Pin Female (Output) | 5-Pin Male (Input) |
| Ground/Shield | Pin 1 | Pin 1 |
| Data (-) signal | Pin 2 | Pin 2 |
| Data (+) signal | Pin 3 | Pin 3 |
| Not used | | Pin 4 |
| Not used | | Pin 5 |

Setting up a DMX Serial Data Link

1. Connect the (male) 3-pin connector side of the DMX cable to the output (female) 3-pin connector of the controller.
2. Connect the end of the cable coming from the controller which will have a (female) 3-pin connector to the input connector of the next fixture consisting of a (male) 3-pin connector.
3. Then, proceed to connect from the output as stated above to the input of the following fixture and so on.

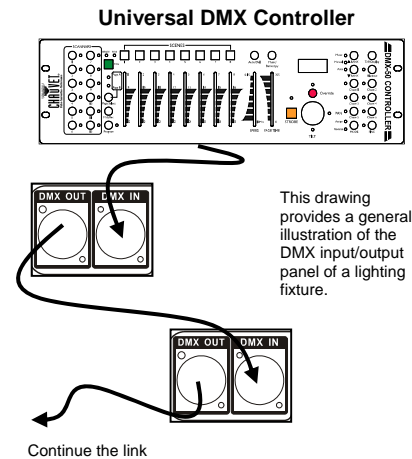

General Maintenance

To maintain optimum performance and minimize wear, fixtures should be cleaned frequently. Usage and environment are contributing factors in determining frequency. As a general rule, fixtures should be cleaned at least twice a month. Dust build up reduces light output performance and can cause overheating. This can lead to reduced lamp life and increased mechanical wear. Be sure to power off fixture before conducting maintenance.

- Unplug fixture from power.
- Use a vacuum or air compressor and a soft brush to remove dust collected on external vents.
- Clean all glass when the fixture is cold with a mild solution of glass cleaner or Isopropyl Alcohol and a soft lint free cotton cloth or lens tissue.
- Apply solution to the cloth or tissue and drag dirt and grime to the outside of the lens.
- Gently polish optical surfaces until they are free of haze and lint.

The cleaning of external optical lenses and/or mirrors must be carried out periodically to optimize light output. Cleaning frequency depends on the environment in which the fixture operates. Damp, smoky or particularly dirty surroundings can cause greater accumulation of dirt on the unit's optics. Clean with soft cloth using normal glass cleaning fluid. Clean the external optics at least every 20 days. Clean the fixture at least every 30/60 days.



Always dry the parts carefully after cleaning them.



Never spin a fan using compressed air.

Returns Procedure

Returned merchandise must be sent prepaid and in the original packing; call tags will not be issued. Package must be clearly labeled with a Return Merchandize Authorization Number (RMA #). Products returned without the RMA # will be refused. Call CHAUVET and request an RMA # prior to shipping the fixture. Be prepared to provide the model number, serial number and a brief description of the cause for the return. Be sure to pack fixture properly; any shipping damage resulting from inadequate packaging is the customer's responsibility. As a suggestion, proper UPS packing or double-boxing is always a safe method to use. CHAUVET reserves the right to use its own discretion to repair or replace product(s).



If you are given an RMA #, please include the following information on a piece of paper inside the box:

- 1) ***Your name***
- 2) ***Your address***
- 3) ***Your phone number***
- 4) ***The RMA #***
- 5) ***A brief description of the symptoms***

Claims

Damage incurred in shipping is the responsibility of the shipper; therefore, the damage must be reported to the carrier upon receipt of merchandise. It is the customer's responsibility to notify and submit claims with the shipper in the event that a fixture is damaged due to shipping. Any other claim for items such as missing component/part, damage not related to shipping, and concealed damage, must be made within seven (7) days of receiving merchandise.

TECHNICAL SPECIFICATIONS

WEIGHT & DIMENSIONS

Length..... 19 in (484 mm)
Width..... 3.8 in (97 mm)
Height..... 5.1 in (130 mm)
Weight..... 3.3 lbs (1.5 kg)

POWER

Auto-ranging power supply 100~240 VAC, 50/60 Hz
Power Consumption @ 120 V 21 W (0.3 A) max, 0.2 A inrush
Power Consumption @ 230 V 23 W (0.2 A) max, 0.3 A inrush
Power output..... 20 units max
Fuse F 1 A, 250 V

LIGHT SOURCE

LED 192 (64 red, 64 green, 64 blue)

PHOTO OPTIC

Lux @ 1 m 820
Beam angle..... 37° x 33°
Field angle 68° x 51°

THERMAL

Maximum ambient temperature 104° F (40° C)

ORDERING INFORMATION

COLORstrip™ Mini COLORSTRIPMINI

WARRANTY INFORMATION

Warranty 2-year limited warranty



5200 NW 108th Ave, Sunrise, FL 33351 U.S.A.
(800) 762-1084 – (954) 929-1115
FAX (954) 929-5560
www.chauvetlighting.com

CONTACT Us

World Wide

General Information

CHAUVET®
5200 NW 108th Ave
Sunrise, FL 33351
voice: 954.929.1115
fax: 954.929.5560
toll free: 800.762.1084

Technical Support

CHAUVET®
5200 NW 108th Ave
Sunrise, FL 33351
voice: 954.929.1115 (**Press 4**)
fax: 954.929.5560 (**Attention: Service**)

World Wide Web

www.chauvetlighting.com