

8130A

Operating Manual
Genelec 8130A
Digital Monitoring System

GENELEC®





System

The Genelec 8130A Digital Monitoring System has a 192 kHz/24 bit digital audio interface allowing you to input digital audio signals straight into the loudspeaker to precisely and directly monitor their audio content.

The 8130A supports all the same modes of operation as the analog Genelec 8030A. You can use it with a subwoofer. You can use it in surround audio systems. You can even use the 8130A as an analog loudspeaker.

Due to its compact size, integrated construction, excellent dispersion and precise stereo imaging, the 8130A is ideal for near field monitoring, mobile vans, digital audio workstations, broadcast and TV control rooms, surround sound systems, home studios, multimedia applications and computer soundcards.

Integrated construction

As the digital interface and amplifiers are built into the loudspeaker enclosure, the only connections required are the mains supply and the input signal, making the 8130A very easy to set up and use.

Digital interface

The digital audio interface comprises a digital audio receiver and a digital-to-analog converter (D/A converter). The 8130A can be used with sampling frequencies up to 192 kHz and word length up to 24 bit. The D/A converter has high resilience to clock jitter and excellent linearity.

Installation

After unpacking, place the loudspeakers in their listening position, taking note of the listening axis (see figure 3). Ensure that the mains switches are set to "OFF" and the volume controls turned fully counterclockwise. Power up the system only after all the connections have been made and turn the volume up carefully.

Signal connectors on the 8130A

The 8130 has three XLR connectors on the back panel (see figure 1):

DIGITAL THRU AES/EBU

This male XLR connector delivers a buffered bit-to-bit copy of the digital input signal. The

connector can be used for daisy-chaining up to eight 8130A's together in digital mode. When the input signal is analog, there is no output from this connector.

DIGITAL IN AES/EBU ANALOG IN

This female XLR connector accepts digital AES/EBU or analog line level signals. The Genelec 8130A detects analog or digital signals and directs them to the right signal paths. In cases where the 8130A is presented with a dual-wire/single channel signal, detection is again automatic and the correct digital input mode is selected.

ANALOG OUT

This male XLR connector delivers a full-bandwidth analog version of the digital or analog audio coming to the input connector. It can be used for daisy-chaining up to eight 8130A's together in analog mode or for connecting a Genelec 7050A subwoofer. In digital mode the signal level from the "ANALOG OUT" connector is controlled by the volume control knob on the front panel and the "SYSTEM LEVEL" switches on the back panel, in analog mode by the volume control knob only.

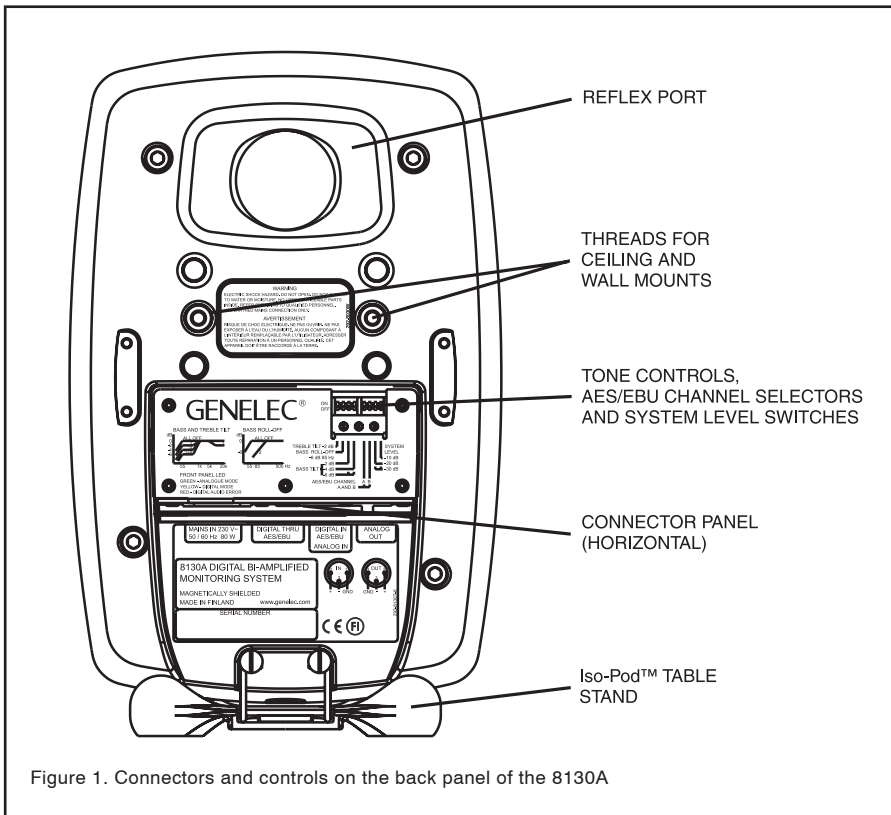

Figure 1. Connectors and controls on the back panel of the 8130A

Connecting the 8130A

Connect your audio signal cable to the female XLR connector labelled ANALOG IN, DIGITAL IN AES/EBU on the 8130A's back panel. The input connector can be fed with either AES/EBU formatted digital signal or analog line level audio signal.

When using digital audio signal, you can identify the right connector on your audio source by looking for the words "Digital Output" or "AES/EBU". Before you connect it to the 8130A you should make absolutely sure that the connector is carrying AES/EBU formatted digital audio signal.

Connect the mains cable to an earthed mains connector, never to an unearthed connector.

Setting up for digital signals

Use the "AES/EBU CHANNEL" switches to select which of the two channels carried by the digital signal you want to be reproduced (A, B or A+B). The factory default setting is A. The 8130A also accepts a dual-wire/single channel signal, which is automatically detected. In this mode the "AES/EBU CHANNEL" switches only affect the output level, which is 6 dB higher when both switches are set to "ON".

The "SYSTEM LEVEL" switches can be used to attenuate the level by 10, 20 or 30 dB. Start with all these switches set to "OFF" and increase the level gradually using the volume control knob. The effect of the switches and volume control knob is cumulative, but consistent attenuation between several loudspeakers is easier to achieve by turning the volume control to maximum setting and using the switches alone.

Level adjustment for analog signals

Note that the "SYSTEM LEVEL" switches on the back panel of the loudspeaker have no effect on the output level when reproducing an analog signal. In this case, use the volume control knob on the front panel to adjust the level.

Mode indicator LED

The mode indicator LED on the front panel of the 8130A changes colour according to the audio signal. Green colour indicates that the loudspeaker is switched on and operating in analog mode. When the loudspeaker detects a valid digital signal being fed to its input connector, the LED turns yellow. A transmission fault is indicated by the LED

turning red. See chapter "Troubleshooting for digital signals."

Troubleshooting for digital signals

The following steps cover some typical causes for faults in monitoring digital signals.

- Make sure that your audio signal source has been set to transmit the audio to the AES/EBU output.
- Make sure the digital interface cable is specified for use with AES/EBU digital audio signals and properly connected at both ends.
- Make sure the LED turns yellow as you plug in the digital audio cable to the 8130A unit. If this is not the case, go back to your audio source and check once more that the correct output is selected. If the LED stays green you do not have a valid digital audio carrier on the cable.
- If you see the LED showing red colour, check your cabling. Red colour indicates a bit error in transmission.

Daisy-chaining several 8130A loudspeakers

There are three alternative configurations for using up to eight 8130A loudspeakers connected together:

Digital master, digital slaves

In this configuration, a digital signal is fed to the first ("master") loudspeaker of the chain and then forwarded through the "DIGITAL THRU AES/EBU" connector to the following "slave" loudspeakers. Each loudspeaker in the chain operates in digital mode and can be individually set to reproduce either A, B or A+B channels carried by the digital signal by using the "AES/EBU CHANNEL" switches as described above. Possible level settings are done to each loudspeaker individually by using the "SYSTEM LEVEL" switches and/or the volume control knob. Note that there is no signal from the "DIGITAL THRU AES/EBU" connector when the input signal is analog. If you need to use several 8130A's daisy-chained together for analog monitoring, connect them through the "ANALOG OUT" connector as described below.

Loudspeaker Mounting Position	Treble Tilt	Bass Tilt	Bass Roll-Off
Free standing in a damped room	OFF	OFF	OFF
Free standing in a reverberant room	OFF	-2 dB	OFF
Near field or console bridge	OFF	-4 dB	OFF
Near to a wall	OFF	-6 dB	OFF
In a corner	OFF	-6 dB	OFF
With a 7050A subwoofer	OFF	OFF	ON

Table 1: Suggested tone control settings for different situations

Digital Signal Input Mode	Channel Monitoring	Switch A	Switch B
Single-wire/dual channel	AES/EBU channel A	ON	OFF
	AES/EBU channel B	OFF	ON
	AES/EBU channel A+B	ON	ON
Dual-wire/single channel	AES/EBU single channel	ON	OFF
	AES/EBU single channel + 6 dB	ON	ON

Table 2: Using the AES/EBU channel selection switches in various input modes.

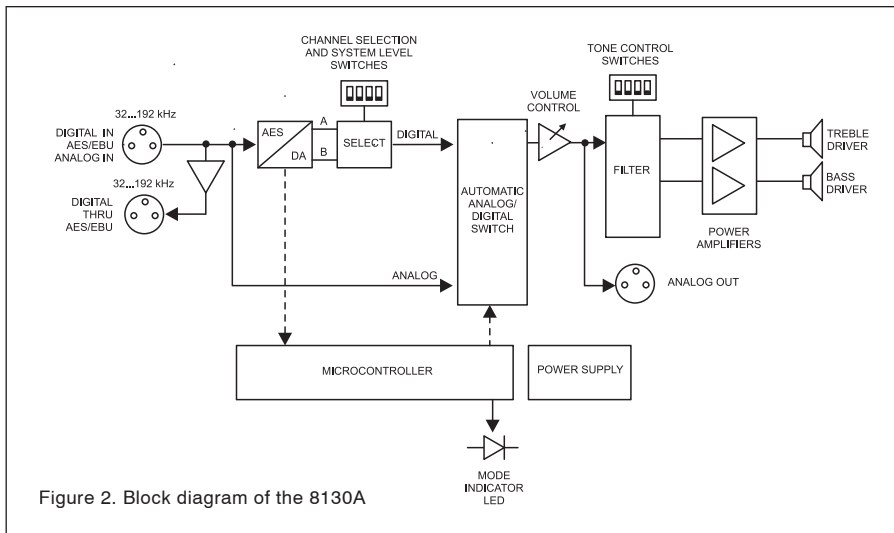

Figure 2. Block diagram of the 8130A

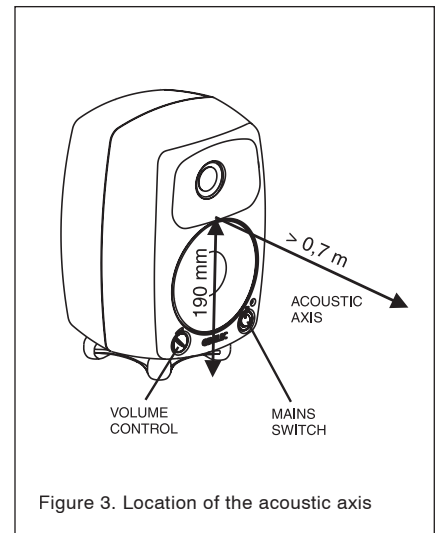

Figure 3. Location of the acoustic axis

Digital master, analog slaves

In this configuration, a digital signal is fed to the first ("master") loudspeaker of the chain and then forwarded through the "ANALOG OUT" connector to the "slave" loudspeakers i.e. the "master" functions in digital mode and the "slaves" in analog mode.

Set the volume control on all "slave" loudspeakers to maximum and use the "SYSTEM LEVEL" switches and volume control knob on the "master" loudspeaker to adjust the level of the whole chain. Also the AES/EBU channel setting (A, B or A+B) on the "master" loudspeaker affects the whole chain.

Analog master, analog slaves

In this configuration, an analog signal is fed to the first ("master") loudspeaker of the chain and then forwarded through the "ANALOG OUT" connector to the "slave" loudspeakers. Set the volume control knob on the "slave" loudspeakers to the maximum setting and use the volume control knob on the "master" loudspeaker to adjust the level of the whole chain.

Setting the tone controls

The frequency response of Genelec 8130A can be adjusted to match the acoustic envi-

ronment by setting the tone control switches on the rear panel. The controls are "Treble Tilt", "Bass Tilt" and "Bass Roll-Off". An acoustic measuring system is recommended for analyzing the effects of the adjustments, however, careful listening with suitable test recordings can also lead to good results if a test system is not available. Table 1 shows some typical settings in various situations. Figure 4 shows the effect of the controls on the anechoic response.

The factory setting for all tone controls is "OFF" to give a flat anechoic response. Always start adjustment by setting all switches to "OFF" position. Measure or listen systematically through the different combinations of settings to find the best frequency balance. The adjustment must always be done individually to each loudspeaker in the system.

Treble Tilt

Treble Tilt (switch 1) attenuates the treble response from 5 kHz up and reaches the attenuation of 2 dB at 15 kHz. This can be used for smoothing down an excessively bright-sounding system.

Bass Tilt

Bass Tilt offers three attenuation levels for the bass response below 1 kHz, usually necessary when the loudspeakers are placed near room boundaries. The attenuation levels are -2 dB (switch 3 "ON"), -4 dB (switch 4 "ON") and -6 dB (both switches "ON").

Bass Roll-Off

Bass Roll-Off (switch 2) activates high-pass filtering at 85 Hz to complement the low-pass filter on a Genelec 7050A subwoofer. This switch should always be set to "ON" when using 8130A's with a 7050A subwoofer.

Mounting considerations

Align the loudspeakers correctly

Always place the loudspeakers so that their acoustic axes (see figure 3) are aimed towards the listening position. Vertical placement is preferable, as it minimises acoustical cancellation problems around the crossover frequency.

Maintain symmetry

Check that the loudspeakers are placed symmetrically and at an equal distance from the

listening position. If possible, place the system so that the listening position is on the centerline of the room and the loudspeakers are placed at an equal distance from the centerline.

Minimise reflections

Acoustic reflections from objects close to the loudspeakers like desks, cabinets, computer monitors etc. can cause unwanted colouration and disturbance of the sound image. These can be minimised by placing the loudspeaker clear of reflective surfaces. For instance, putting the loudspeakers on stands behind and above the mixing console usually gives a better result than placing them on the meter bridge.

Minimum clearances

Sufficient cooling for the amplifier and functioning of the reflex port must be ensured if the loudspeaker is installed in a restricted space such as a cabinet or integrated into a wall structure. The surroundings of the loudspeaker must always be open to the listening room with a minimum clearance of 5 centimeters (2") behind, above and on both sides of the loudspeaker. The space adjacent to the amplifier must either be ventilated or sufficiently large to dissipate heat so that the ambient temperature does not rise above 35 degrees Celsius (95°F)

Mounting options

The 8130A offers several mounting options: The Iso-Pod™ (Isolation Positioner/Decoupler™) vibration insulating table stand allows tilting the loudspeaker for correct alignment of the acoustic axis. The stand can be attached to three mounting points allowing vertical and symmetrical horizontal positioning. Vertical installation is recommended. On the base of the loudspeaker is a 3/8" UNC threaded hole compatible with a standard microphone stand. On the rear there are two M6x10 mm threaded holes for Omnimount® size 20.5 brackets.

Maintenance

No user serviceable parts are to be found within the loudspeaker. Any maintenance or repair of the 8130A unit should only be undertaken by qualified service personnel.

Safety considerations

Although the 8130A has been designed in accordance with international safety stand-

ards, the following warnings and cautions should be observed to ensure safe operation and to maintain the loudspeaker under safe operating conditions:

- Servicing and adjustment must only be performed by qualified service personnel. The loudspeaker must not be opened.
- Do not use this product with an unearthed mains cable as this may compromise electrical safety.
- Do not expose the loudspeaker to water or moisture. Do not place any objects filled with liquid, such as vases, on the loudspeaker or near it.
- Do not place naked flame sources like lighted candles on or near the loudspeaker.
- This loudspeaker is capable of producing sound pressure levels in excess of 85 dB, which may cause permanent hearing damage.
- Free flow of air behind the loudspeaker is necessary to maintain sufficient cooling. Do not obstruct airflow around the loudspeaker.
- Note that the amplifier is not completely disconnected from the AC mains service unless the mains power cord is removed from the amplifier or the mains outlet.

Compliance to FCC Rules

This device complies with part 15 of the FCC Rules. Operation is subject to the following two conditions:

- This device may not cause harmful interference, and
- This device must accept any interference received, including interference that may cause undesired operation.

Note: This equipment has been tested and found to comply with the limits for a Class B digital device, pursuant to part 15 of the FCC Rules. These limits are designed to provide reasonable protection against harmful interference in a residential installation. This equipment generates, uses and can radiate radio frequency energy and, if not installed and used in accordance with the instructions, may cause harmful interference to radio communications. However, there is no guarantee that interference will not occur in a particular installation. If this equipment does

cause harmful interference to radio or television reception, which can be determined by turning the equipment off and on, the user is encouraged to try to correct the interference by one or more of the following measures:

- Reorient or relocate the receiving antenna.
- Increase the separation between the equipment and receiver.
- Connect the equipment into an outlet on a circuit different from that to which the receiver is connected.
- Consult the dealer or an experienced radio/TV technician for help.

Modifications not expressly approved by the manufacturer could void the user's authority to operate the equipment under FCC rules.

EC Declaration of Conformity

This is to certify that Genelec Digital Monitoring System 8130A conforms to the following standards:

Safety:

EN 60065 / IEC 60065:1998 7th Edition

EMC:

EN 55013: (2001)

EN 55020: (1994), A11: (1996), A12: (1999),

A13: (1999), A14: (1999)

EN 61000-3-2 (2000)

EN 61000-3-3 (1995)

The product herewith complies with the requirements of The Low Voltage Directive 73/23/EEC, EMC Directive 89/336/EEC and 93/68/EEC

Signed: 

Ilpo Martikainen

Position: Managing Director

Date: 25-November-2004

Guarantee

Genelec 8130A is supplied with a one year guarantee against manufacturing faults or defects that might alter the performance of the loudspeaker. Refer to the supplier for full sales and guarantee terms.

8130A Operating Manual

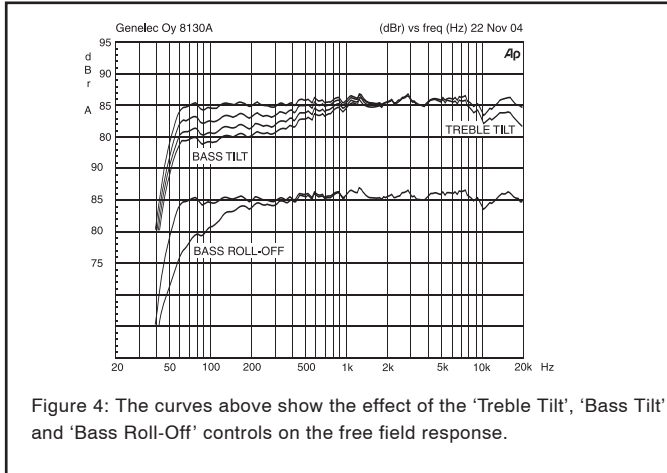

Figure 4: The curves above show the effect of the 'Treble Tilt', 'Bass Tilt' and 'Bass Roll-Off' controls on the free field response.

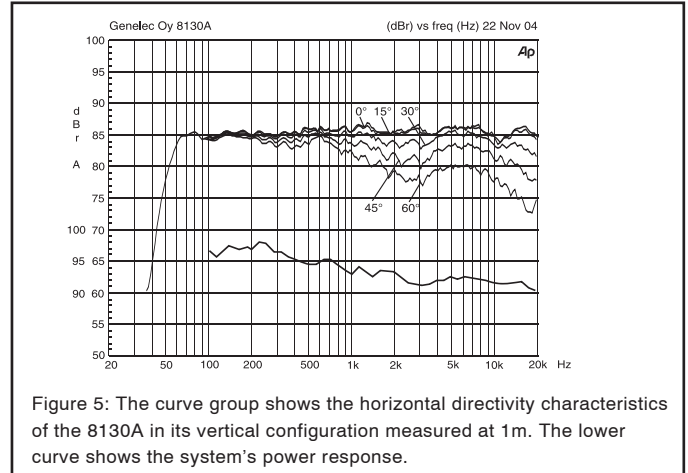

Figure 5: The curve group shows the horizontal directivity characteristics of the 8130A in its vertical configuration measured at 1m. The lower curve shows the system's power response.

SYSTEM SPECIFICATIONS

Lower cut-off frequency, -3 dB:	≤ 55 Hz
Upper cut-off frequency, -3 dB:	≥ 21 kHz
Free field frequency response of system:	58 Hz – 20 kHz (± 2.0 dB)
Maximum short term sine wave acoustic output on axis in half space, averaged from 100 Hz to 3 kHz:	
	@ 1 m ≥ 100 dB SPL
	@ 0.5 m ≥ 106 dB SPL
Maximum long term RMS acoustic output in same conditions with IEC weighted noise (limited by driver unit protection circuit):	@ 1 m ≥ 97 dB SPL
Maximum peak acoustic output per pair on top of console, @ 1 m from the engineer with music material:	≥ 108 dB
Self generated noise level in free field @ 1 m on axis:	≤ 10 dB (A-weighted)
Harmonic distortion at 85 dB SPL @ 1 m on axis:	
Freq:	50...100 Hz < 2 %
	> 100 Hz < 0.5 %
Drivers:	
Bass	130 mm (5") cone
Treble	19 mm (3/4") metal dome
	Both drivers are magnetically shielded
Weight:	5.6 kg (12.3 lb)
Dimensions:	
Height	299 mm (11 ¹³ / ₁₆ ")
(including Iso-Pod™ table stand)	
Height	285 mm (11 ¹ / ₄ ")
(without Iso-Pod™ table stand)	
Width	189 mm (7 ⁷ / ₁₆ ")
Depth	178 mm (7")

CROSSOVER SECTION

Analog connectors:	
Input connector:	XLR female, (DIGITAL IN AES/EBU, ANALOG IN) balanced 10 kOhm, pin 1 gnd, pin 2 +, pin 3 -
Analog output:	XLR male, (ANALOG OUT) balanced 100 Ohm, pin 1 gnd, pin 2 +, pin 3 -
Input level for 100 dB SPL output at 1 m:	-6 dBu at volume control max
Volume control range:	-80 dB relative to max output
Output signal level is 0 dB relative to input signal level but adjustable by volume control	
Crossover frequency, Bass/Treble:	3.0 kHz
Treble Tilt control operating range:	0 to -2 dB @ 15 kHz
Bass Roll-Off control operating in a -6 dB step @ 85 Hz (to be used in conjunction with a 7050A subwoofer)	
Bass Tilt control operating range in -2 dB steps:	0 to -6 dB @ 100 Hz
The 'CAL' position is with all tone controls set to 'off' and the input sensitivity control to maximum (fully clockwise).	

DIGITAL SECTION

Input connector (DIGITAL IN AES/EBU, ANALOG IN)	XLR female
DIGITAL THRU connector	XLR male
Word length:	16...24 bits
Input format:	AES/EBU
Input termination impedance:	110 Ohm
Input sampling rate:	29-200 kHz (no de-emphasis)
Dynamic range:	>113 dB (A weighted, triangular PDF dither, 24 bit data)

AMPLIFIER SECTION

Bass amplifier output power with an 8 Ohm load:	40 W
Treble amplifier output power with an 8 Ohm load:	40 W
Long term output power is limited by driver unit protection circuitry.	
Amplifier system distortion at nominal output:	
THD	≤ 0.05 %
SMPTE-IM	≤ 0.05 %
CCIF-IM	≤ 0.05 %
DIM 100	≤ 0.05 %
Signal to Noise ratio, referred to full output:	
Bass	≥ 100 dB
Treble	≥ 100 dB
Mains voltage:	100, 120, 220 or 230 V according to region
Voltage operating range:	±10 %
Power consumption:	Idle 15 VA
	Full output 80 VA