

TECHNO STROBE™ 168

User Manual

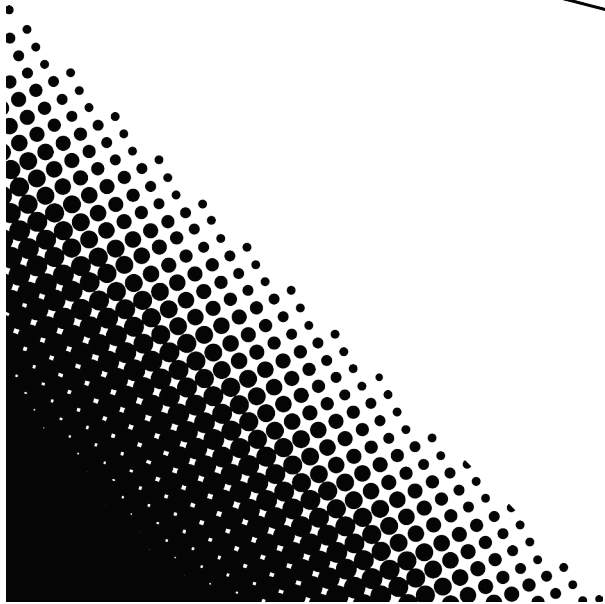
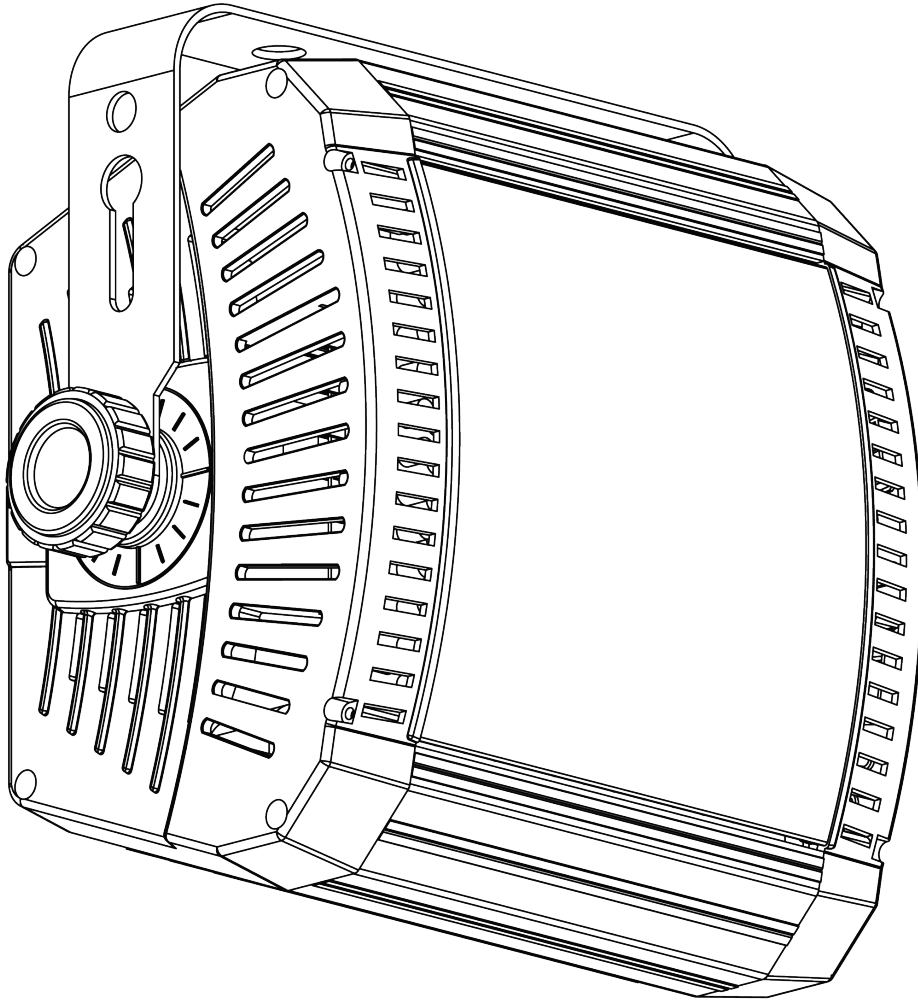

CHAUVET®
Value • Innovation • Performance
It's
Green Thinking.™

TABLE OF CONTENTS

1. Before You Begin	3
What Is Included	3
Unpacking Instructions	3
Claims	3
Text Conventions	3
Symbols	3
Disclaimer	3
Product at a Glance	4
Safety Notes	4
2. Introduction	5
Overview	5
Dimensions	6
3. Setup	7
AC Power	7
Fuse Replacement	7
Power Linking	8
Mounting	9
Orientation	9
Rigging	9
4. Operation	10
Configuration (DMX)	10
Starting Address	10
DIP Switch Reference Guide	11
DMX Channel Modes, Assignments, and Values	12
2-Channel	12
Configuration (Standalone)	12
Sound-Active Mode	12
Strobe Mode	12
Full On Mode	12
Master/Slave Mode	13
5. Technical Information	14
Product Maintenance	14
6. Technical Specifications	15
Returns	16
Contact Us	16

1. BEFORE YOU BEGIN

What Is Included

- Techno Strobe™ 168
- Power Cord
- Warranty Card
- Quick Reference Guide

Unpacking Instructions

Carefully unpack the product immediately and check the container to make sure all the parts are in the package and are in good condition.

Claims



If the box or the contents (the product and included accessories) appear damaged from shipping, or show signs of mishandling, notify the carrier immediately, not CHAUVET®. Failure to report damage to the carrier immediately may invalidate your claim. In addition, keep the box and contents for inspection.

For other issues, such as missing components or parts, damage not related to shipping, or concealed damage, file a claim with CHAUVET® within 7 days of delivery.

Text Conventions

Convention	Meaning
[10]	A DIP switch to be configured
1~512	A range of values
50/60	A set of values of which only one can be chosen
Settings	A menu option not to be modified
Menu > Settings	A sequence of menu options to be followed
<ENTER>	A key to be pressed on the product's control panel
ON	A value to be entered or selected

Symbols

Symbol	Meaning
	Critical installation, configuration, or operation information. Not following these instructions may make the product not work, cause damage to the product, or cause harm to the operator.
	Important installation or configuration information. The product may not function correctly if this information is not used.
	Useful information.

Disclaimer

The information and specifications contained in this User Manual are subject to change without notice. CHAUVET® assumes no responsibility or liability for any errors or omissions, and reserves the right to revise or recreate this manual at any time. Download the latest version from www.chauvetlighting.com.

© Copyright 2013 CHAUVET®. All rights reserved.

Electronically published by CHAUVET® in the United States of America.

Author	Date	Editor	Updated
A. Leon	10/25/12	S. Diaz	1/28/13

Product at a Glance

Use on Dimmer	⊘	Auto Programs	✓
Outdoor Use	⊘	Auto-ranging Power Supply	✓
Sound-Active	✓	Replaceable Fuse	✓
DMX	✓	User-Serviceable	⊘
Master/Slave	✓	Duty Cycle	⊘

Safety Notes

These notes include important information about the mounting, usage, and maintenance of this product; read before using the product.



- Always connect the product to a grounded circuit to avoid the risk of electrocution.
- Always disconnect the product from the power source before cleaning or replacing the fuse.
- Avoid direct eye exposure to the light source while the product is on.
- Make sure the power cord is not crimped or damaged.
- Never disconnect the product from power by pulling or tugging on the cord.
- If mounting the product overhead, always secure to a fastening device using a safety cable.
- Make sure there are no flammable materials close to the product when operating.
- Do not touch the product's housing when operating because it may be very hot.



- Always make sure that the voltage of the outlet to which you are connecting the product is within the range stated on the decal or rear panel of the product.
- The product is for indoor use only! (IP20) To prevent risk of fire or shock, do not expose the product to rain or moisture.
- Always install the product in a location with adequate ventilation, at least 20 in (50 cm) from adjacent surfaces.
- Be sure that no ventilation slots on the product's housing are blocked.
- Never connect the product to a dimmer.
- Make sure to replace the fuse with another of the same type and rating.
- Never carry the product from the power cord or any moving part. Always use the hanging/mounting bracket.
- The maximum ambient temperature (Ta) is 104° F (40° C). Do not operate the product at higher temperatures.
- In the event of a serious operating problem, stop using the product immediately.
- Never try to repair the product. Repairs carried out by unskilled people can lead to damage or malfunction. Contact the nearest authorized technical assistance center.
- This product is not intended for permanent installation.



- Keep this User Manual for future use. If you sell the product to another user, be sure to give this document to the next owner.

2. INTRODUCTION

Overview

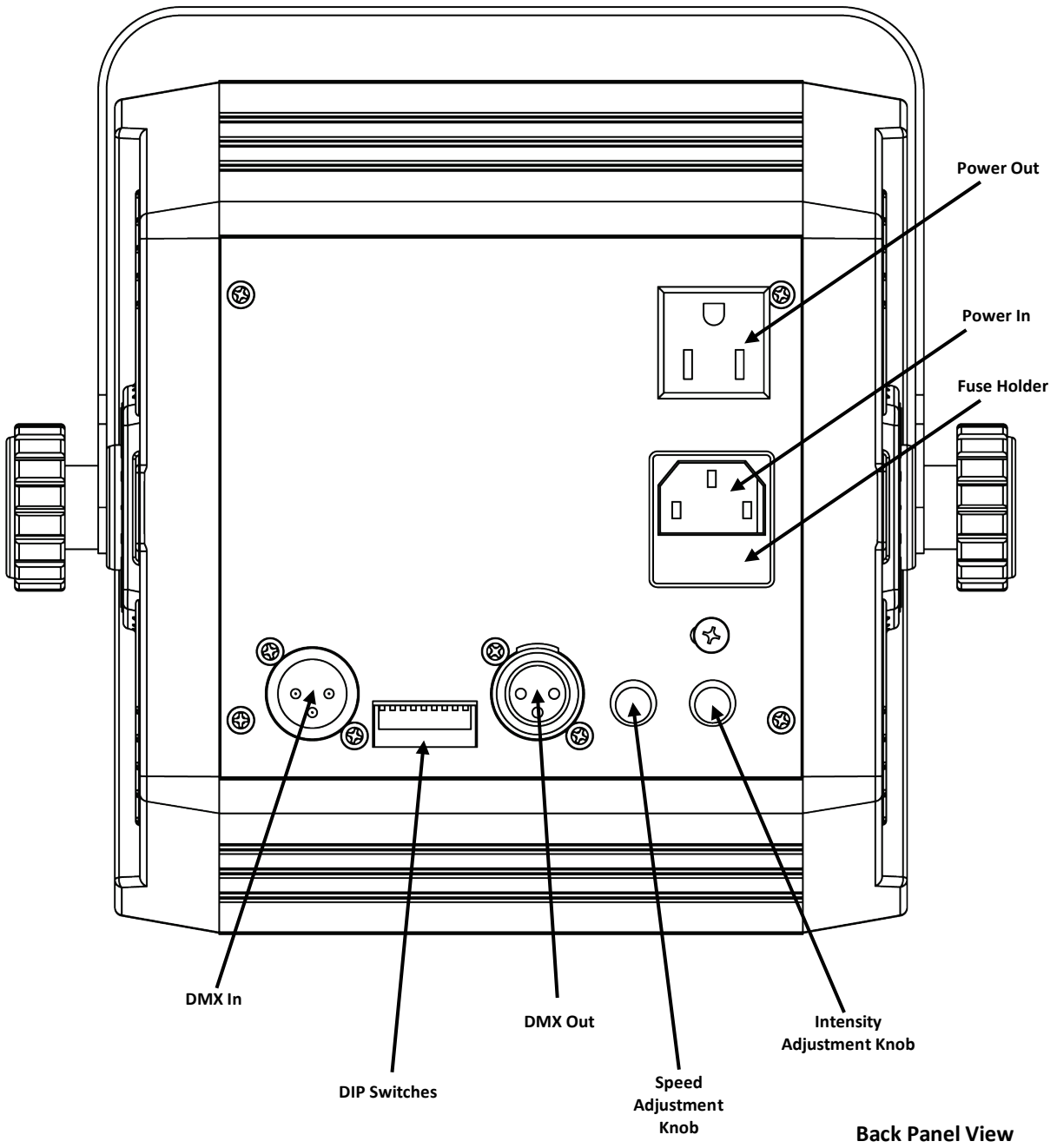

Dimensions

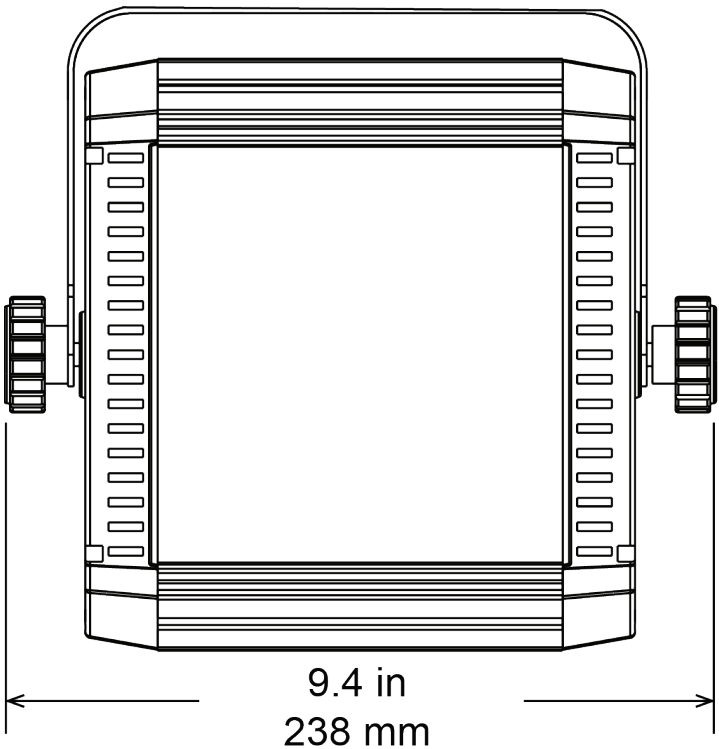
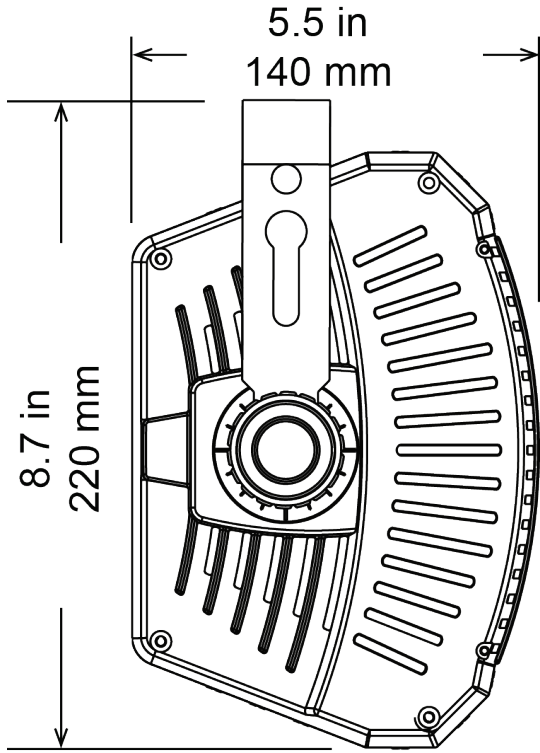

3. SETUP

AC Power The Techno Strobe™ 168 has an auto-ranging power supply and it can work with an input voltage range of 100~240 VAC, 50/60 Hz.

To determine the product's power requirements (circuit breaker, power outlet, and wiring), use the current value listed on the label affixed to the product's back panel, or refer to the product's specifications chart. The listed current rating indicates the product's average current draw under normal conditions.



Always connect the product to a protected circuit (circuit breaker or fuse). Make sure the product has an appropriate electrical ground to avoid the risk of electrocution or fire.



Never connect the product to a rheostat (variable resistor) or dimmer circuit, even if the rheostat or dimmer channel serves only as a 0~100% switch.

Fuse Replacement



Disconnect the product from power before replacing the fuse.

1. Disconnect the product from power.
2. Wedge the tip of a flat-head screwdriver into the slot of the fuse holder.
3. Pry the fuse holder out of the housing.
4. Remove the blown fuse from the holder.
5. Replace with a fuse of the exact same type and rating.
6. Insert the fuse holder back in place and reconnect power.

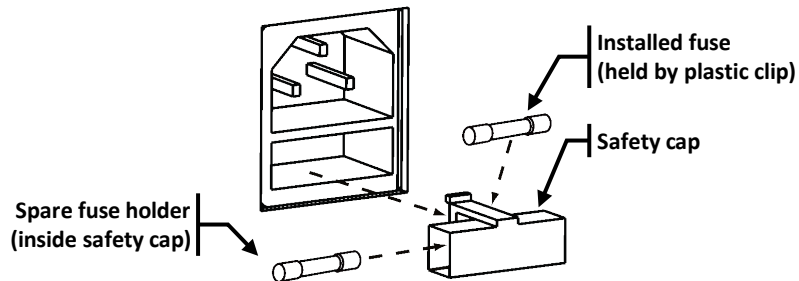

A spare fuse is not included; however, the safety cap has room for a spare.



Always replace a blown fuse with another of the same type and rating.

Power Linking The product provides power linking via the Edison/IEC outlet located in the back of the unit.

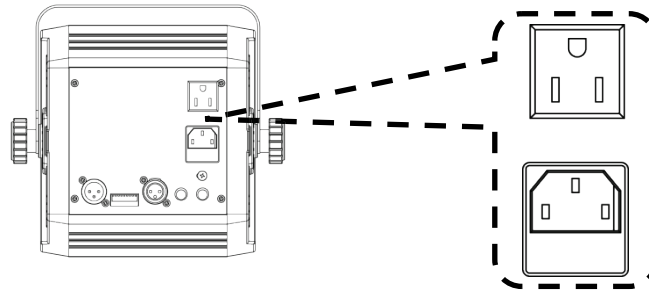

Power Linking Diagram

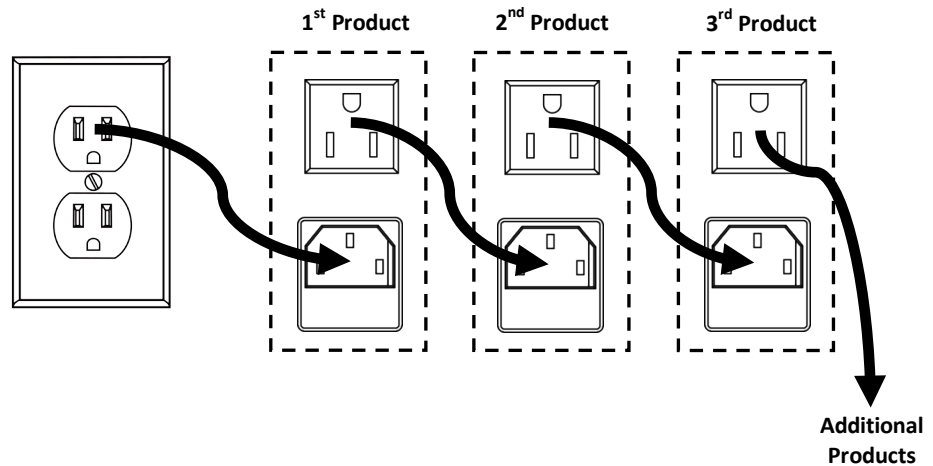

You can power link up to 34 Techno Strobe™ 168 units on 120 VAC or up to 57 Techno Strobe™ 168 units on 230 VAC.



The power linking diagram shown above corresponds to the North American version of the product ONLY! If using the product in other markets, you must consult with the local CHAUVET® distributor as power linking connectors and requirements may differ in your country or region.

Mounting Before mounting the product, read and follow the safety recommendations indicated in the Safety Notes.

Orientation The Techno Strobe™ 168 may be mounted in any position; however, make sure adequate ventilation is provided around the product.

- Rigging**
- Before deciding on a location, always make sure there is easy access to the product for maintenance and programming.
 - Make sure that the structure or surface onto which you are mounting the product can support the product's weight (see the [Technical Specifications](#)).
 - When mounting the product overhead, always use a safety cable. Mount the product securely to a rigging point, such as an elevated platform or a truss.
 - When rigging the product onto a truss, you should use a mounting clamp of appropriate weight capacity. The bracket has 13-mm holes, which are appropriate for this purpose.
 - When power linking multiple products, you must always consider the length of the power linking cable and mount the products close enough for the cable to reach.
 - The bracket adjustment knobs allow for directional adjustment when aiming the product to the desired angle. Only loosen or tighten the bracket knobs manually. Using tools could damage the knobs.
 - The mounting bracket also serves as floor supports/allow for surface mounting. When mounting the product on the floor, make sure that the product and cables are away from people and vehicles.

**Mounting
Diagram**

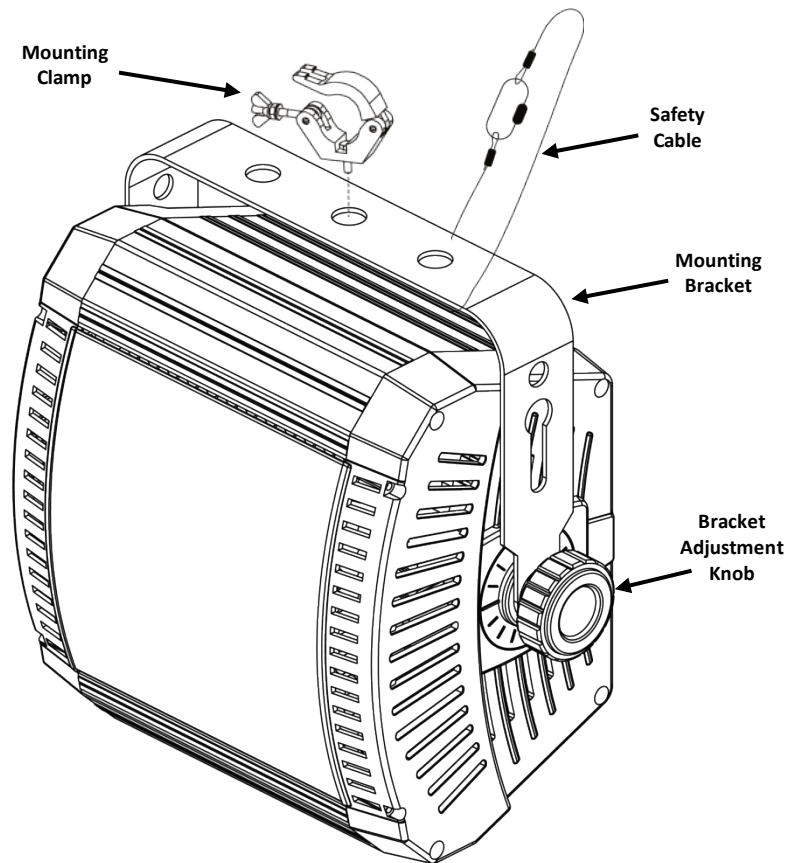

4. OPERATION

Configuration (DMX)

Set the product in DMX mode to control with a DMX controller.

1. Connect the product to a suitable power outlet.
2. Connect a DMX cable from the DMX output of the DMX controller to the DMX input socket on the product.

Starting Address

When selecting a starting DMX address, always consider the number of DMX channels the selected DMX mode uses. If you choose a starting address that is too high, you could restrict the access to some of the product's channels.

The Techno Strobe™ 168 uses up to 2 DMX channels in its 2-channel personality DMX mode, which defines the highest configurable address to **511**. The DMX starting address is configured through the DIP switches located on the back panel.

If unfamiliar with DMX or DIP switches, download the DMX Primer from www.chauvetlighting.com.

Starting Address Settings

DIP Switch	1	2	3	4	5	6	7	8	9
Value	1	2	4	8	16	32	64	128	256

Select the desired starting address by setting DIP switches [1]~[9] to **On** or **Off** until the sum of the value of the DIP switches in the **On** position matches the desired address number.

Refer to the examples below for more information.

Starting Address Examples

1. To select DMX address **1**, set DIP switch [1] to **On**.
2. To select DMX address **64**, set DIP switch [7] to **On**.
3. To select DMX address **31**, set DIP switches [1], [2], [3], [4], and [5] to **On**.
(1 + 2 + 4 + 8 + 16 = 31)

DIP Switch Reference Guide

You can use the table below to set your fixture's DIP switches. Imagine that you want to find the DIP switch settings for DMX address **328**:

1. Find **328** among the addresses from the table and point at it with your finger.
2. Move your finger to the left and you will find the settings for DIP switches [1]~[5].
DIP switches [1], [2], [3], and [5] are **Off** (0), while DIP switch [4] is **On** (1).
3. Go back and point at the **328** address.
4. Move your finger upward and you will find the settings for DIP switches [6]~[9].
DIP switches [6] and [8] are **Off** (0), while DIP switches [7] and [9] are **On** (1).
5. See below how the DIP switches will look after configuring them.

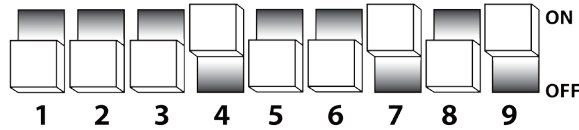

DIP Switches 0 = Off 1 = On		#9	0	0	0	0	0	0	0	0	0	1	1	1	1	1	1	1	1	
		#8	0	0	0	0	1	1	1	1	0	0	0	0	1	1	1	1	1	
		#7	0	0	1	1	0	0	1	1	0	0	1	1	0	0	1	1	1	
		#6	0	1	0	1	0	1	0	1	0	1	0	1	0	1	0	1	0	1
#1	#2	#3	#4	#5	DMX Address															
0	0	0	0	0	---	32	64	96	128	160	192	224	256	288	320	352	384	416	448	480
1	0	0	0	0	1	33	65	97	129	161	193	225	257	289	321	353	385	417	449	481
0	1	0	0	0	2	34	66	98	130	162	194	226	258	290	322	354	386	418	450	482
1	1	0	0	0	3	35	67	99	131	163	195	227	259	291	323	355	387	419	451	483
0	0	1	0	0	4	36	68	100	132	164	196	228	260	292	324	356	388	420	452	484
1	0	1	0	0	5	37	69	101	133	165	197	229	261	293	325	357	389	421	453	485
0	1	1	0	0	6	38	70	102	134	166	198	230	262	294	326	358	390	422	454	486
1	1	1	0	0	7	39	71	103	135	167	199	231	263	295	327	359	391	423	455	487
0	0	0	1	0	8	40	72	104	136	168	200	232	264	296	328	360	392	424	456	488
1	0	0	1	0	9	41	73	105	137	169	201	233	265	297	329	361	393	425	457	489
0	1	0	1	0	10	42	74	106	138	170	202	234	266	298	330	362	394	426	458	490
1	1	0	1	0	11	43	75	107	139	171	203	235	267	299	331	363	395	427	459	491
0	0	1	1	0	12	44	76	108	140	172	204	236	268	300	332	364	396	428	460	492
1	0	1	1	0	13	45	77	109	141	173	205	237	269	301	333	365	397	429	461	493
0	1	1	1	0	14	46	78	110	142	174	206	238	270	302	334	366	398	430	462	494
1	1	1	1	0	15	47	79	111	143	175	207	239	271	303	335	367	399	431	463	495
0	0	0	0	1	16	48	80	112	144	176	208	240	272	304	336	368	400	432	464	496
1	0	0	0	1	17	49	81	113	145	177	209	241	273	305	337	369	401	433	465	497
0	1	0	0	1	18	50	82	114	146	178	210	242	274	306	338	370	402	434	466	498
1	1	0	0	1	19	51	83	115	147	179	211	243	275	307	339	371	403	435	467	499
0	0	1	0	1	20	52	84	116	148	180	212	244	276	308	340	372	404	436	468	500
1	0	1	0	1	21	53	85	117	149	181	213	245	277	309	341	373	405	437	469	501
0	1	1	0	1	22	54	86	118	150	182	214	246	278	310	342	374	406	438	470	502
1	1	1	0	1	23	55	87	119	151	183	215	247	279	311	343	375	407	439	471	503
0	0	0	1	1	24	56	88	120	152	184	216	248	280	312	344	376	408	440	472	504
1	0	0	1	1	25	57	89	121	153	185	217	249	281	313	345	377	409	441	473	505
0	1	0	1	1	26	58	90	122	154	186	218	250	282	314	346	378	410	442	474	506
1	1	0	1	1	27	59	91	123	155	187	219	251	283	315	347	379	411	443	475	507
0	0	1	1	1	28	60	92	124	156	188	220	252	284	316	348	380	412	444	476	508
1	0	1	1	1	29	61	93	125	157	189	221	253	285	317	349	381	413	445	477	509
0	1	1	1	1	30	62	94	126	158	190	222	254	286	318	350	382	414	446	478	510
1	1	1	1	1	31	63	95	127	159	191	223	255	287	319	351	383	415	447	479	511

DMX Channel Modes, Assignments, and Values

2-Channel	Channel	Function	Value	Percent/Setting
	1	Control Functions	000 ⇔ 005 006 ⇔ 240 241 ⇔ 250 251 ⇔ 255	No function Strobe speed, slow to fast Full On (all LEDs on) Sound-Active mode
	2	Dimmer	000 ⇔ 255	0~100%

Configuration (Standalone) Set the product in one of the standalone modes to control without a DMX controller. The standalone modes are accessed through the DIP switches located on the back panel.

1. Connect the product to a suitable power outlet.



Never connect a product that is operating in any standalone mode (either Static, Automatic, or Sound) to a DMX string connected to a DMX controller. Products in standalone mode may transmit DMX signals that could interfere with the DMX signals from the controller.

Sound-Active Mode To enable the Sound-Active mode, do the following:

1. Set all DIP switches to **Off**.
2. Turn the Speed Adjustment knob counterclockwise to the minimum position.
3. Turn the Intensity Adjustment knob until the product starts responding to the beat of the music.



The product will only respond to low frequencies of music (bass and drums).

Strobe Mode To enable the Strobe mode, do the following:

1. Set all DIP switches to **Off**.
2. Turn the Speed Adjustment knob between the minimum and maximum positions to the desired strobe speed.

All-On Mode To enable the All-On mode, do the following:

1. Set all DIP switches to **Off**.
2. Turn the Speed Adjustment knob clockwise to the maximum position.



Due to its innovate design, this unit can be run strobing all night, but continuous All-On operation should not be used for more than 30 minutes at 120V or 15 minutes at 230V.

Master/Slave Mode

The Master/Slave mode allows a single Techno Strobe™ 168 unit (the “master”) to control the actions of one or more Techno Strobe™ 168 units (the “slaves”) without the need of a DMX controller. The master unit will be set to operate in Manual or Sound-Active mode, while the slave units will be set to the same DMX starting address. Once set and connected, the slave units will operate in unison with the master unit.

Configure the units as indicated below.

Slave units:

1. Set the DMX address to **1**.
2. Connect the DMX input of the subsequent slave units to the DMX output of the previous slave unit.
3. Finish setting and connecting all the slave units.
4. Connect the DMX input of the first slave unit to the DMX output of the master unit.

Master unit:

1. Set the master unit to operate in Manual or Sound-Active mode.
2. Make the master unit the first unit in the DMX daisy chain.



- **Configure all the slave units before connecting the master unit to the DMX daisy chain.**
- **Never connect a DMX controller to a DMX string configured for Master/Slave operation because the controller may interfere with the signals from the master unit.**
- **Do not connect more than 31 slave units to the master unit.**

5. TECHNICAL INFORMATION

Product Maintenance

Dust build-up reduces light output performance and can cause overheating. This can lead to reduction of the light source's life. To maintain optimum performance and minimize wear, clean the product at least twice a month. However, usage and environmental conditions contribute to increased cleaning frequency.

To clean the product, follow the instructions below:

- Unplug the product from power.
- Wait until the product is at room temperature.
- Use a vacuum (or dry compressed air) and a soft brush to remove dust collected on the external surface/vents.
- Clean all glass/transparent surfaces with a mild soap solution, ammonia-free glass cleaner, or isopropyl alcohol.
- Apply the solution directly to a soft, lint-free cotton cloth or a lens cleaning tissue.
- Softly wipe any dirt or grime to the outside edges of the glass/transparent surface.
- Gently polish the glass/transparent surfaces until they are free of haze and lint.



Always dry the glass/transparent surfaces carefully after cleaning them.

6. TECHNICAL SPECIFICATIONS

Dimensions and Weight	Length	Width	Height	Weight
	5.5 in (140 mm)	9.4 in (238 mm)	8.7 in (220 mm)	2.3 lbs (1.0 kg)
Note: Dimensions in inches rounded to the nearest decimal digit.				
Power	Power Supply Type	Range	Voltage Selection	
	Switching (internal)	100~240 V, 50/60 Hz	Auto-ranging	
	Parameter	120 V, 60 Hz	230 V, 50 Hz	
	Consumption	28 W	32 W	
	Operating current	0.2 A	0.1 A	
Power I/O	Power I/O	U.S./Worldwide	UK/Europe	
	Power input connector	IEC	IEC	
	Power output connector	Edison	IEC	
	Power Cord plug	Edison (U.S.)	Local plug	
Light Source	Type	LED		
	Color	Quantity	White	
Photo Optic	Parameter	Quantity		
	Illuminance @ 2 m	500 lx		
	Beam angle	24°		
	Field angle	44		
Thermal	Strobe Rate	0~12 Hz		
	Maximum External Temp.	Cooling System	104° F (40° C)	
DMX	Cooling System	Convection		
	I/O Connectors	Connector Type	Channel Range	
Ordering	3-pin XLR	Sockets	2	
	Product Name	Item Code	UPC Number	
Techno Strobe™ 168	16050595	781462209438		

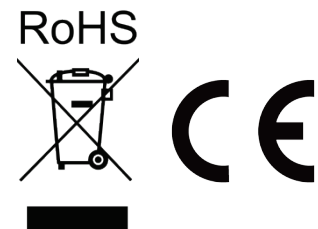

To return a product or request support:

- In the U.S., contact CHAUVET® World Headquarters (see below).
- In the UK or Ireland, contact CHAUVET® Europe Ltd. (see below).
- In any other country, DO NOT contact CHAUVET®. Contact your distributor. See www.chauvetlighting.com for distributors outside the U.S., United Kingdom, or Ireland.



If you live outside the U.S., United Kingdom, or Ireland, contact your distributor of record and follow their instructions on how to return CHAUVET® products to them. Visit our website for contact details.

Returns

Call the corresponding CHAUVET® Technical Support office and request a Return Merchandise Authorization (RMA) number before shipping the product. Be prepared to provide the model number, serial number, and a brief description of the cause for the return.

You must send the merchandise prepaid, in its original box, and with its original packing and accessories. CHAUVET® will not issue call tags.

Clearly label the package with the RMA number. CHAUVET® will refuse any product returned without an RMA number.



Write the RMA number on a properly affixed label. DO NOT write the RMA number directly on the box.

Before sending the product, clearly write the following information on a piece of paper and place it inside the box:

- Your name
- Your address
- Your phone number
- The RMA number
- A brief description of the problem

Be sure to pack the product properly. Any shipping damage resulting from inadequate packaging will be your responsibility. FedEx packing or double-boxing are recommended.



CHAUVET® reserves the right to use its own discretion to repair or replace returned product(s).

Contact Us

World Headquarters

CHAUVET®

General Information

Address: 5200 NW 108th Avenue
Sunrise, FL 33351
Voice: (954) 577-4455
Fax: (954) 929-5560
Toll free: (800) 762-1084

Technical Support

Voice: (954) 577-4455 (Press 4)
Fax: (954) 756-8015
Email: tech@chauvetlighting.com

World Wide Web

www.chauvetlighting.com

United Kingdom & Ireland

CHAUVET® Europe Ltd.

General Information

Address: Unit 1C
Brookhill Road Industrial Estate
Pinxton, Nottingham, UK
NG16 6NT
Voice: +44 (0)1773 511115
Fax: +44 (0)1773 511110

Technical Support

Email: uktech@chauvetlighting.com

World Wide Web

www.chauvetlighting.co.uk