

# COLORrail™ IRC

*User Manual*

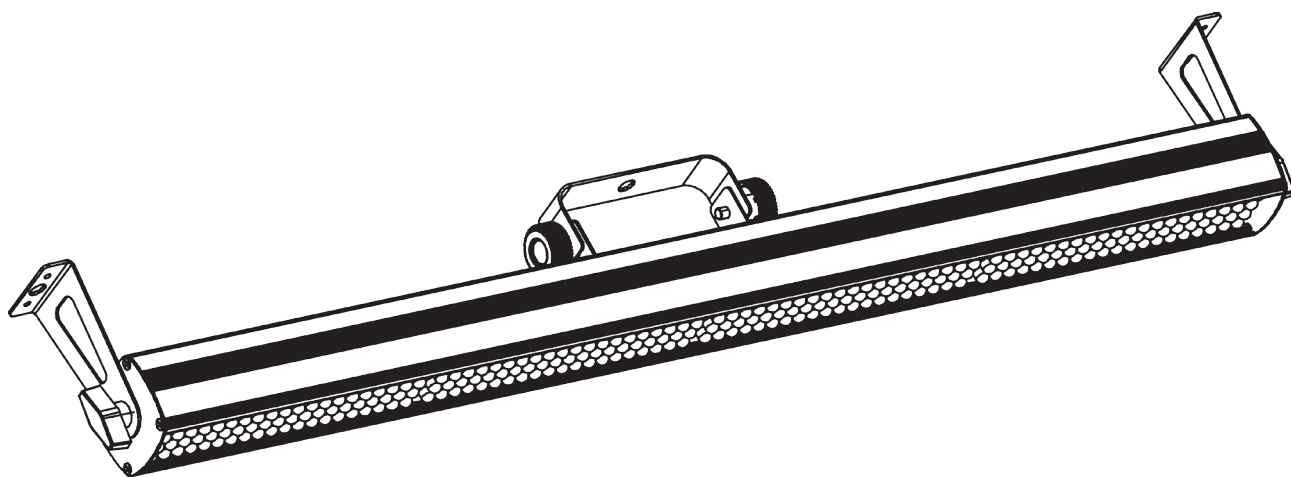

**CHAUVET**®  
Value • Innovation • Performance  
It's  
**Green Thinking.**™

---

# TABLE OF CONTENTS

<b>1. Before you Begin</b> .....	<b>3</b>
What is Included.....	3
Unpacking Instructions .....	3
Text Conventions .....	3
Icons .....	3
Safety Notes .....	4
<b>2. Introduction</b> .....	<b>5</b>
Product Overview.....	5
<b>3. Setup</b> .....	<b>6</b>
AC Power.....	6
Power Linking .....	6
Mounting .....	7
Orientation.....	7
Rigging.....	7
<b>4. Operation</b> .....	<b>8</b>
Control Panel Operation .....	8
<b>Menu Map</b> .....	8
Configuration (DMX).....	9
Starting Address .....	9
Configuration (Standalone Modes) .....	10
Sound Active Mode.....	10
Automatic Mode.....	10
Wireless Remote Mode .....	10
<i>Master/Slave Mode</i> .....	11
Program Selection.....	11
Static Color .....	11
IRC (Infrared Remote Control) Operation.....	12
DMX Channel Assignments and Values.....	13
26-CH.....	13
14-CH.....	14
7-CH.....	15
4-CH.....	16
3-CH.....	16
2-CH.....	16
<b>5. Technical Information</b> .....	<b>17</b>
General Maintenance .....	17
Returns Procedure .....	17
Claims.....	18
Contact Information .....	18
<b>6. Technical Specifications</b> .....	<b>19</b>

# 1. BEFORE YOU BEGIN

## What is Included

- 1 x COLORrail™ IRC
- 1 x Bracket kit
- 1 x Power Cord
- 1 x Warranty Card
- 1 x User Manual

## Unpacking Instructions



Immediately upon receiving this product, carefully unpack it and check the container in which you received it. Make sure that you have received all the parts indicated above and that they are all in good condition. If the material inside the container (this product and any other accessory included with it) appears damaged from shipping, or if the container shows signs of mishandling, notify the shipper immediately. In addition, retain the container and all the packing material for inspection.

See the *Claims* section in the “*Technical Information*” chapter.

## Text Conventions

Convention	Meaning
[10]	A DIP switch to be configured
<Menu>	A key to be pressed on the fixture's control panel
1~512	A range of values
50/60	A set of values of which only one can be chosen
<i>Settings</i>	A menu option not to be modified (for example, showing the operating mode/current status)
<i>Menu &gt; Settings</i>	A sequence of menu options to be followed
ON	A value to be entered or selected

## Icons

Icon	Meaning
	Critical installation, configuration, or operation information. Failure to comply with this information may render the fixture partially or completely inoperative, cause damage to the fixture, or cause harm to the user.
	Important installation or configuration information. Failure to comply with this information may prevent the fixture from functioning correctly.
	Useful information.

## Document Information

The information and specifications contained in this document are subject to change without notice. CHAUVET® assumes no responsibility or liability for any errors or omissions that may appear in this manual.

© Copyright 2012 CHAUVET®. All rights reserved.

Printed in P.R.C.

Electronically published by CHAUVET® in the United States of America.

<b>Author</b> A. Chiappone
-------------------------------

---

## Product at a Glance

Use on Dimmer	⊘	Auto Programs	✓
Outdoor Use	⊘	Auto-ranging Power Supply	✓
Sound Activated	✓	Replaceable Fuse	✓
DMX	✓	User Serviceable	⊘
Master/Slave	✓	Duty Cycle	⊘

## Safety Notes



**Please read the following notes carefully because they include important safety information about the installation, usage, and maintenance of this product.**

- Keep this User Manual for future consultation. If you sell this product to another user, be sure that they also receive this document.
- Always make sure that the voltage of the outlet to which you are connecting this product is within the range stated on the decal or rear panel of the fixture.
- This product is for indoor use only! To prevent risk of fire or shock, do not expose this fixture to rain or moisture.
- Make sure there are no flammable materials close to the unit while operating.
- Always install this product in a location with adequate ventilation, at least 20 in (50 cm) from adjacent surfaces.
- Always disconnect this product from the power source before cleaning it or replacing the fuse.
- Make sure to replace the fuse with another of the same type and rating.
- If mounting this product overhead, always secure it to a fastening device using a safety cable.
- The maximum ambient temperature (Ta) is 104° F (40° C). Do not operate this product at higher temperatures.
- In the event of a serious operating problem, stop using the unit immediately.
- Never try to repair this product. Repairs carried out by unskilled people can lead to damage or malfunction. Please contact the nearest authorized technical assistance center.
- Never connect this product to a dimmer pack.
- Make sure the power cord is not crimped or damaged.
- Never disconnect the power cord by pulling or tugging on the cord.
- Never carry a fixture from the power cord or any moving part. Always use the hanging/mounting bracket or the handles.
- Always avoid direct eye exposure to the light source when this fixture is on.

---

## 2. INTRODUCTION

### Product Overview

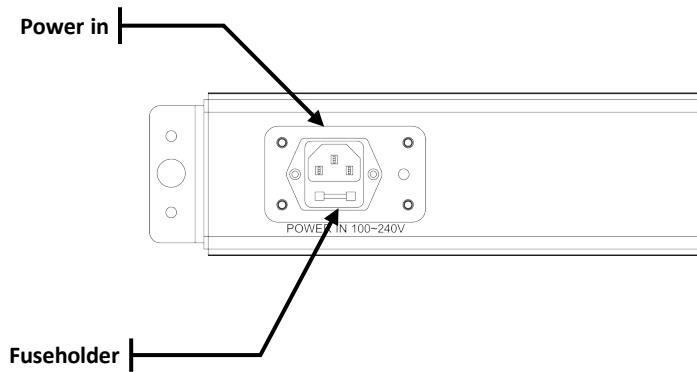
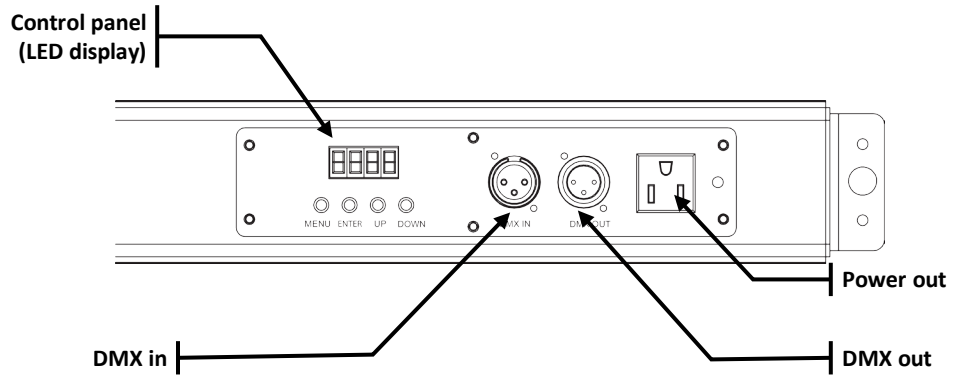

# 3. SETUP

## AC Power

This product has an auto-ranging power supply and it can work with an input voltage range of 100~240 VAC, 50/60 Hz.

To determine the power requirements for a particular fixture, see the label affixed to the back plate of the fixture or refer to the fixture's specifications chart. A fixture's listed current rating indicates its average current draw under normal conditions.



**Always connect this product to a protected circuit (circuit breaker or fuse), making sure that it has an appropriate electrical ground to avoid the risk of electrocution or fire.**



**Never connect this product to a rheostat (variable resistor) or dimmer circuit, even if the rheostat or dimmer channel serves only as a 0 to 100% switch.**

## Power Linking

This fixture provides power linking via the Edison/IEC outlet located in the back of the unit. Please see the diagram below for further explanation.

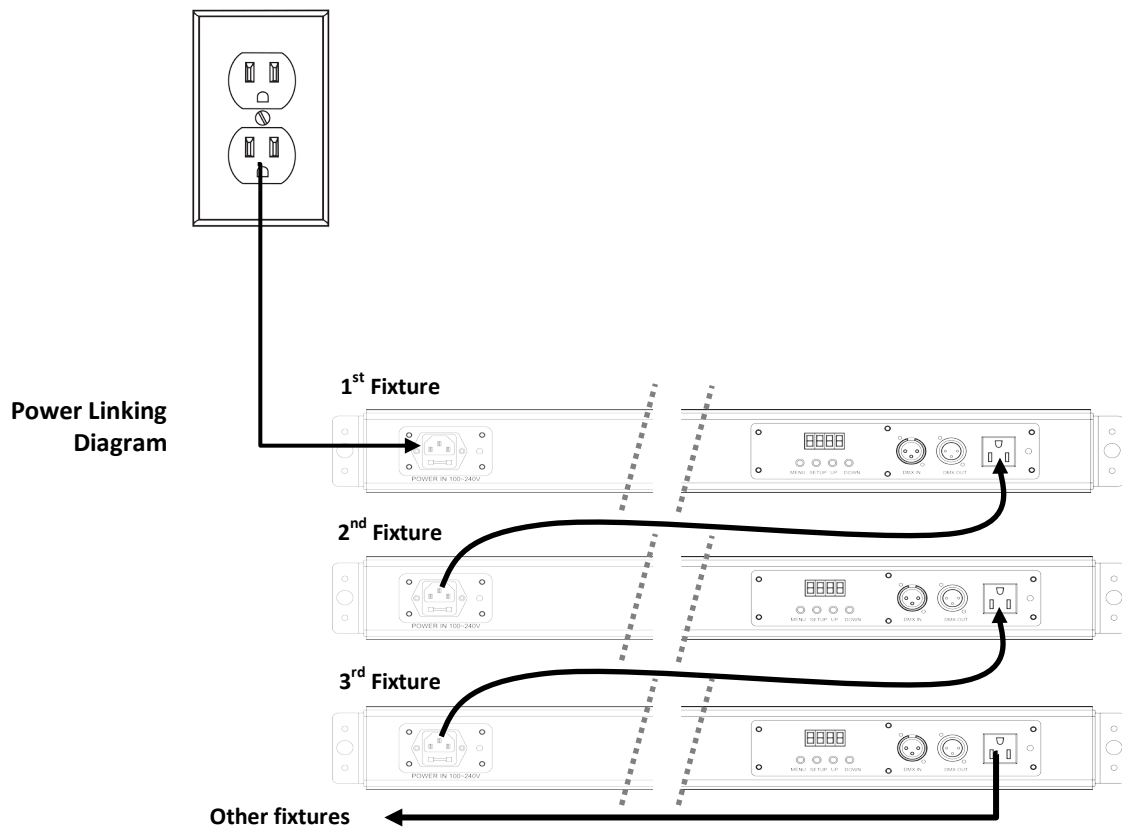

**You can power link up to 17 COLORrail™ IRC units on 120 VAC or up to 32 COLORrail™ IRC units on 230 VAC.**



**The power linking diagram shown above corresponds to the North American version of this product ONLY! If using this product in other markets, you must consult with the local CHAUVET® distributor as power linking connectors and requirements may differ in your country or region.**

---

## Mounting

### Orientation

The COLORrail™ IRC may be mounted in any position, provided there is adequate room for ventilation around it.

### Rigging

Be sure that the structure or surface onto which you are mounting this product can support its weight. Please see the “Technical Specifications” section of this manual for weight information.

Make sure to mount the fixture securely to a rigging point, whether an elevated platform or a truss.

When rigging this product onto a truss, you should use a mounting clamp of appropriate weight capacity. The bracket has a 13 mm hole, which is appropriate for this purpose.

When mounting this product overhead, always use a safety cable.

Before deciding on a location for this product, always make sure that it will be easy to access the unit for maintenance and programming purposes.

When power linking multiple fixtures, you must always consider the length of the power linking cable and mount the fixtures close enough for the cable to reach them.

The bracket knobs allow for directional adjustment when aiming the fixture to the desired angle. Only loosen or tighten the bracket knobs using your bare hands. Using tools could damage the knobs.

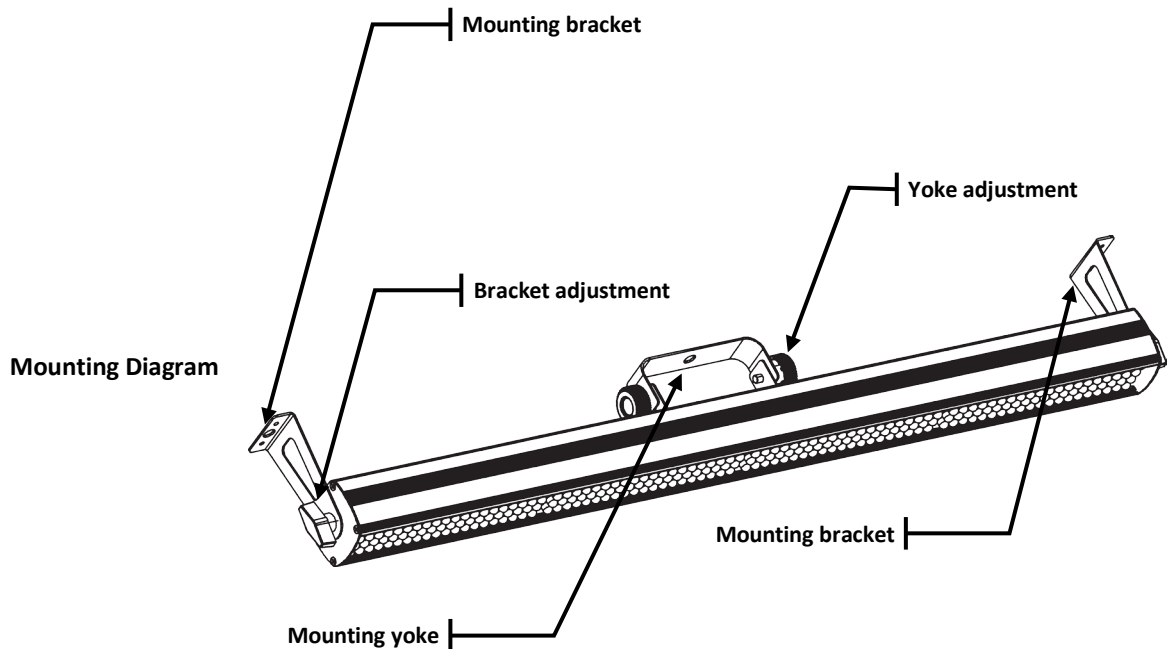

***There are two (2) rigging options available for this product. If using the mounting brackets, then you must use both of them. If using the mounting yokes, then it is only necessary to use a single mounting point.***

# 4. OPERATION

## Control Panel Operation

To access the control panel functions, use the four buttons located underneath the display.

Button	Function
<MENU>	Press to find an operation mode or to back out of the current menu option
<ENTER>	Press to activate a menu option or a selected value
<UP>	Press to scroll up the list of options or to find a higher value
<DOWN>	Press to scroll down the list of options or to find a lower value

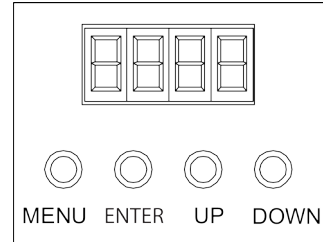

## Menu Map

Main Level	Programming Levels		Description	
Auto Run	AUR	n__	01-99, FL Number of loops	
		S.__	01-99, FL Run speed (slow to fast)	
		F._	00-99 Strobe speed (slow to fast)	
DMX Channel and Personalities	001	001-512	Sets DMX address	
	__c	2-c	Sets DMX personality	
		3-c		
		4-c		
		7-c		
		14c		
		26c		
Slave Mode	SLA		Sets Slave functionality	
IR Controller	ir-		IRC functionality	
Auto Programs	P.01	1.-r	Red	
		2.r9	Yellow	
		3.-9	Green	
		4.9b	Cyan	
		5.-b	Blue	
		6.rb	Magenta	
		7.FL	White	
		8.OF	Off	
		F.01-F.99	Strobe speed (slow to fast)	
		S. 01-S.99, S.FL	Run speed (slow to fast)	
	P.02-P.20	F.00-F.99	Strobe speed (slow to fast)	
		S. 01-S.99, S.FL	Run speed (slow to fast)	
	P.__	P.21-P.22	F.00-F.99	Strobe speed (slow to fast)
			1.-r	Foreground color
			1.r9	
			1.-9	
			1.9b	
			1.-b	
		1.rb	Background color	
		1.FL		
		1.FF		
		2.-r		
2.r9				
2.-9				
2.9b				
2.-b				
2.rb				
2.FL				
2.FF	Off			



---

## Configuration (DMX)

Set this product in DMX mode to control it with a DMX controller.

- 1) Connect this product to a suitable power outlet.
- 2) Turn this product on.
- 3) Connect a DMX cable from the DMX output of the DMX controller to the DMX input socket of this product.

### Starting Address

When selecting a starting DMX address, always consider the number of DMX channels the selected DMX mode uses. If you choose a starting address that is too high, you could restrict the access to some of the fixture's channels.

The COLORrail™ IRC uses up to 26 DMX channels in its highest DMX mode, which defines the highest configurable address to 487.

If you are not familiar with the DMX protocol, you may refer to the “DMX Primer” section in the *“Technical Information”* chapter.

To select the starting address, do the following:

- 1) Press **<MENU>** repeatedly until **d001~512** shows on the display.
- 2) Press **<ENTER>**.
- 3) Use **<UP>** or **<DOWN>** to select the starting address.
- 4) Press **<ENTER>**.
- 5) Use **<UP>** or **<DOWN>** to select the personality.
- 6) Press **<ENTER>**.

---

## Configuration (Standalone Modes)

Set this product in one of the standalone modes to control it without a DMX controller.

- 1) Connect this product to a suitable power outlet.
- 2) Turn this product on.

### Sound Active Mode

To enable the Sound Active mode, do the following:

- 1) Press **<MENU>** repeatedly until **SU\*\*** shows on the display.
- 2) Press **<ENTER>**.
- 3) Use **<UP>** or **<DOWN>** to adjust the microphone sensitivity.
- 4) Press **<ENTER>**.



The fixture will only respond to the low frequencies of the music (bass and drums).

### Automatic Mode



Never connect a fixture that is operating in any standalone mode, whether Static, Automatic, or Sound to a DMX string connected to a DMX controller. This is because fixtures in standalone mode may transmit DMX signals that could interfere with the DMX signals from the controller.

To enable the Automatic Mode, follow the instructions below:

- 1) Press **<MENU>** repeatedly until **AUTO** shows on the display.
- 2) Press **<ENTER>**.



You may determine the number of times a single program will play back before proceeding to the next program, using *n001~100*.

### Wireless Remote Mode

To enable the Wireless Remote Mode, follow the instructions below:

- 1) Press **<MENU>** repeatedly until **-ir-** shows on the display.
- 2) Press **<ENTER>**.

---

## Master/Slave Mode

This mode allows a single COLORrail™ IRC unit (the “master”) to control the actions of one or more COLORrail™ IRC units (the “slaves”) without the need of a DMX controller. The master unit will be set to operate in either Automatic or Sound Active mode, while the slave units will be set to operate in Slave Mode. Once set and connected, the slave units will operate in unison with the master unit.

Configure the units as indicated below.

### Slave units:

- 1) Press **<MODE>** repeatedly until **SLAU** shows on the display.
- 2) Press **<ENTER>** to accept.
- 3) Set the DMX address to “001”, as previously explained.
- 5) Connect the DMX input of the first slave unit to the DMX output of the master unit.
- 6) Connect the DMX input of the subsequent slave units to the DMX output of the previous slave unit.
- 7) Finish setting and connecting all the slave units.

### Master unit:

- 1) Set the master unit to operate in either Automatic or Sound mode, as previously indicated.
- 2) Make the master unit the first unit in the DMX daisy chain.



- **Configure all the slave units before connecting the master unit to the DMX daisy chain.**
- **Never connect a DMX controller to a DMX string configured for Master/Slave operation because it may interfere with the signals from the master unit.**
- **Do not connect more than 31 slave units to the master unit.**

## Program Selection

To enable the Program Selection mode, do the following:

- 1) Press **<MENU>** repeatedly until **Pr\*\*** shows on the display.
- 2) Press **<ENTER>**.
- 3) Use **<UP>** or **<DOWN>** to select the desired program (**01~20**).
- 4) Press **<ENTER>** to cycle through the different playback modifications. See the “Menu Map” for details on which modifications are available.
- 5) Press **<ENTER>** when you arrive at the desired modification.
- 6) Use **<UP>** or **<DOWN>** to adjust the parameter of the modification.
- 7) Press **<ENTER>**.



**Programs 01, 21, and 22 have unique options available. For this reason, they have been listed in a separate section in the “Menu Map”. The available options allow you to select one of 7 preset colors for both the background and the foreground.**

## Static Color

To enable the Static Color mode, do the following:

- 1) Press **<MENU>** repeatedly until **CoLr** shows on the display.
- 2) Press **<ENTER>** to scroll through the three colors (red, green, blue).
- 3) Use **<UP>** or **<DOWN>** to modify the intensity of each color, thereby creating a custom color mix.
- 4) Press **<ENTER>** when you arrive at the desired modification.
- 5) Use **<UP>** or **<DOWN>** to adjust the parameter of the modification (**000~255**).
- 6) Press **<ENTER>**.

---

## IRC (Infrared Remote Control) Operation

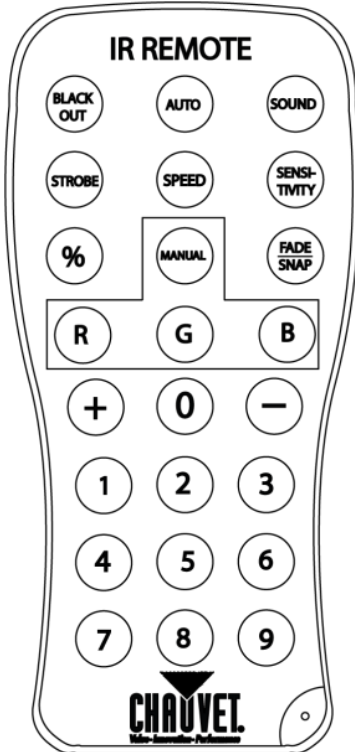

### Automatic Mode

Automatic Mode will enable you to run the automatic programs on the product.

To turn on Automatic Mode:

1. Press AUTO on the IRC.
2. Press + or – to choose between the different auto programs.

To adjust the speed of the automatic program:

1. Press SPEED on the IRC.
2. Press %.
3. Press + or – to either increase or decrease the speed of the program.

### Sound Active Mode

Sound Active Mode will enable the product to respond to the music.

To turn on Sound Active mode:

1. Press SOUND on the IRC.

To adjust sound sensitivity in Sound Active mode:

1. Press SENSITIVITY on the IRC.
2. Press %.
3. Press + or – to either increase or decrease sound sensitivity.

### Manual Color Control

To choose a specific color with the IRC:

1. Press MANUAL on the IRC.
2. Press any number between 0-9 to choose your color.

To manually control the RGB percentage:

1. Press MANUAL on the IRC.
2. Press R, G, or B to choose your color.
3. Press + or – to increase or decrease the percentage of each color.

### Miscellaneous Operation

To adjust the strobe rate of the program:

1. Press STROBE on the IRC.
2. Press + or – to increase or decrease the strobe rate.
3. Press STROBE again to turn off the strobe.

To change the switching effect of the program:

Press FADE/SNAP on the IRC.

Fade will slowly switch the effect. Snap will rapidly switch the effect.

To black out the lights:

Press BLACK OUT on the IRC.

This will turn off all the lights until the button is pressed again.

**Note:** The IRC will not respond to any inputs when Black Out is activated. If the remote does not respond when a button is pressed, try pressing BLACK OUT. You may have inadvertently activated BLACK OUT.

# DMX Channel Assignments and Values

## 26-CH

CHANNEL	VALUE	FUNCTION	CHANNEL	VALUE	FUNCTION
1	000 ⇔ 255	<b>Master Dimmer</b> 0~100%	14	000 ⇔ 255	<b>Red (section 5)</b> Dimmer: 0~100%
2	000 ⇔ 255	<b>Red (section 1)</b> Dimmer: 0~100%	15	000 ⇔ 255	<b>Green (section 5)</b> Dimmer: 0~100%
3	000 ⇔ 255	<b>Green (section 1)</b> Dimmer: 0~100%	16	000 ⇔ 255	<b>Blue (section 5)</b> Dimmer: 0~100%
4	000 ⇔ 255	<b>Blue (section 1)</b> Dimmer: 0~100%	17	000 ⇔ 255	<b>Red (section 6)</b> Dimmer: 0~100%
5	000 ⇔ 255	<b>Red (section 2)</b> Dimmer: 0~100%	18	000 ⇔ 255	<b>Green (section 6)</b> Dimmer: 0~100%
6	000 ⇔ 255	<b>Green (section 2)</b> Dimmer: 0~100%	19	000 ⇔ 255	<b>Blue (section 6)</b> Dimmer: 0~100%
7	000 ⇔ 255	<b>Blue (section 2)</b> Dimmer: 0~100%	20	000 ⇔ 255	<b>Red (section 7)</b> Dimmer: 0~100%
8	000 ⇔ 255	<b>Red (section 3)</b> Dimmer: 0~100%	21	000 ⇔ 255	<b>Green (section 7)</b> Dimmer: 0~100%
9	000 ⇔ 255	<b>Green (section 3)</b> Dimmer: 0~100%	22	000 ⇔ 255	<b>Blue (section 7)</b> Dimmer: 0~100%
10	000 ⇔ 255	<b>Blue (section 3)</b> Dimmer: 0~100%	23	000 ⇔ 255	<b>Red (section 8)</b> Dimmer: 0~100%
11	000 ⇔ 255	<b>Red (section 4)</b> Dimmer: 0~100%	24	000 ⇔ 255	<b>Green (section 8)</b> Dimmer: 0~100%
12	000 ⇔ 255	<b>Green (section 4)</b> Dimmer: 0~100%	25	000 ⇔ 255	<b>Blue (section 8)</b> Dimmer: 0~100%
13	000 ⇔ 255	<b>Blue (section 4)</b> Dimmer: 0~100%	26	000 ⇔ 000 001 ⇔ 255	<b>Strobe</b> No Function Strobe 1~100%

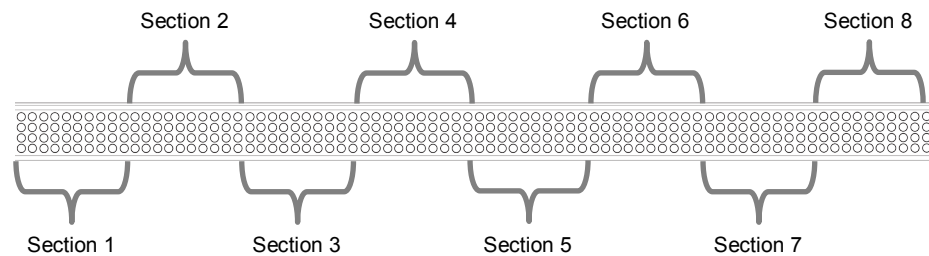

## 14-CH

CHANNEL	VALUE	FUNCTION	CHANNEL	VALUE	FUNCTION
1	000 ⇔ 255	<b>Master Dimmer</b> 0~100%	8	000 ⇔ 255	<b>Red (section 3)</b> Dimmer: 0~100%
2	000 ⇔ 255	<b>Red (section 1)</b> Dimmer: 0~100%	9	000 ⇔ 255	<b>Green (section 3)</b> Dimmer: 0~100%
3	000 ⇔ 255	<b>Green (section 1)</b> Dimmer: 0~100%	10	000 ⇔ 255	<b>Blue (section 3)</b> Dimmer: 0~100%
4	000 ⇔ 255	<b>Blue (section 1)</b> Dimmer: 0~100%	11	000 ⇔ 255	<b>Red (section 4)</b> Dimmer: 0~100%
5	000 ⇔ 255	<b>Red (section 2)</b> Dimmer: 0~100%	12	000 ⇔ 255	<b>Green (section 4)</b> Dimmer: 0~100%
6	000 ⇔ 255	<b>Green (section 2)</b> Dimmer: 0~100%	13	000 ⇔ 255	<b>Blue (section 4)</b> Dimmer: 0~100%
7	000 ⇔ 255	<b>Blue (section 2)</b> Dimmer: 0~100%	14	000 ⇔ 000 001 ⇔ 255	<b>Strobe</b> No Function Strobe 1~100%

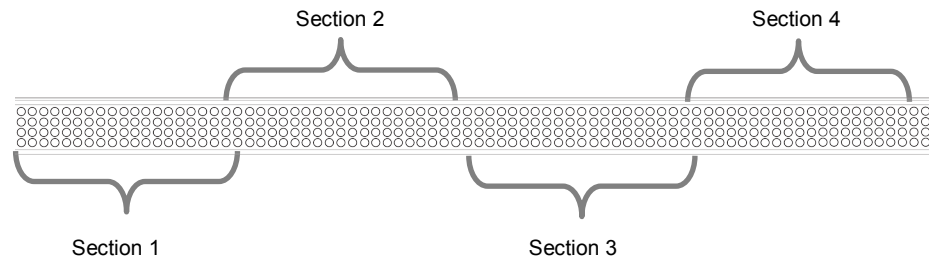

## 7-CH

CHANNEL	VALUE	FUNCTION
1	000 ⇄ 255	<b>Master Dimmer</b> 0~100%
2	000 ⇄ 255	<b>Red</b> Dimmer: 0~100%
3	000 ⇄ 255	<b>Green</b> Dimmer: 0~100%
4	000 ⇄ 255	<b>Blue</b> Dimmer: 0~100%
5	000 ⇄ 007	<b>Color Macro</b> No Function
	008 ⇄ 015	Red
	016 ⇄ 023	Yellow
	024 ⇄ 031	Green
	032 ⇄ 039	Cyan
	040 ⇄ 047	Blue
	048 ⇄ 055	Purple
	056 ⇄ 063	White
	064 ⇄ 071	Auto Program 1
	072 ⇄ 079	Auto Program 2
	080 ⇄ 087	Auto Program 3
	088 ⇄ 095	Auto Program 4
	096 ⇄ 103	Auto Program 5
	104 ⇄ 111	Auto Program 6
	112 ⇄ 119	Auto Program 7
	120 ⇄ 127	Auto Program 8
	128 ⇄ 135	Auto Program 9
	136 ⇄ 143	Auto Program 10
144 ⇄ 151	Auto Program 11	
152 ⇄ 159	Auto Program 12	
160 ⇄ 167	Auto Program 13	
168 ⇄ 175	Auto Program 14	
176 ⇄ 183	Auto Program 15	
184 ⇄ 191	Auto Program 16	
192 ⇄ 199	Auto Program 17	
200 ⇄ 207	Auto Program 18	
208 ⇄ 215	Auto Program 19	
216 ⇄ 223	Auto Program 20	
224 ⇄ 231	Auto Program 21	
232 ⇄ 255	Sound Mode	
6	000 ⇄ 255	<b>Auto Program Speed (When CH.5 is between 64~231)</b> <b>Sound Sensitivity (When CH.5 is between 232-255)</b> 0~100%
7	000 ⇄ 000	<b>Strobe</b> No Function
	001 ⇄ 255	Strobe 1~100%

## 4-CH

CHANNEL	VALUE	FUNCTION
1	000 ⇔ 255	<b>Master Dimmer</b> 0~100%
2	000 ⇔ 255	<b>Red</b> Dimmer: 0~100%
3	000 ⇔ 255	<b>Green</b> Dimmer: 0~100%
4	000 ⇔ 255	<b>Blue</b> Dimmer: 0~100%

## 3-CH

CHANNEL	VALUE	FUNCTION
1	000 ⇔ 255	<b>Red</b> Dimmer: 0~100%
2	000 ⇔ 255	<b>Green</b> Dimmer: 0~100%
3	000 ⇔ 255	<b>Blue</b> Dimmer: 0~100%

## 2-CH

CHANNEL	VALUE	FUNCTION
1	000 ⇔ 007	<b>Color Macro</b>
	008 ⇔ 015	No Function
	016 ⇔ 023	Red
	024 ⇔ 031	Yellow
	032 ⇔ 039	Green
	040 ⇔ 047	Cyan
	048 ⇔ 055	Blue
	056 ⇔ 063	Purple
	064 ⇔ 071	White
	072 ⇔ 079	Auto Program 1
	080 ⇔ 087	Auto Program 2
	088 ⇔ 095	Auto Program 3
	096 ⇔ 103	Auto Program 4
	104 ⇔ 111	Auto Program 5
	112 ⇔ 119	Auto Program 6
	120 ⇔ 127	Auto Program 7
	128 ⇔ 135	Auto Program 8
	136 ⇔ 143	Auto Program 9
	144 ⇔ 151	Auto Program 10
	152 ⇔ 159	Auto Program 11
	160 ⇔ 167	Auto Program 12
	168 ⇔ 175	Auto Program 13
176 ⇔ 183	Auto Program 14	
184 ⇔ 191	Auto Program 15	
192 ⇔ 199	Auto Program 16	
200 ⇔ 207	Auto Program 17	
208 ⇔ 215	Auto Program 18	
216 ⇔ 223	Auto Program 19	
224 ⇔ 231	Auto Program 20	
232 ⇔ 255	Auto Program 21	
2	000 ⇔ 255	<b>Sound Mode</b>
	000 ⇔ 255	<b>Auto Program Speed (When CH.1 is between 64~231)</b> 0~100%



---

## 5. TECHNICAL INFORMATION

### General Maintenance

Dust build up reduces light output performance and can cause overheating. This can lead to reduction of the light source's life. To maintain optimum performance and minimize wear, you should clean your lighting fixtures at least twice a month. However, be aware that usage and environmental conditions could be contributing factors to increase the cleaning frequency.

To clean this fixture, follow the instructions below:

- Unplug the fixture from power.
- Wait until the fixture is cold.
- Use a vacuum (or dry compressed air) and a soft brush to remove dust collected on the external surface.
- Apply the solution directly to a soft, lint free cotton cloth or a lens cleaning tissue.

### Returns Procedure

The user must send the merchandise prepaid, in the original box, and with its original packing and accessories. CHAUVET® will not issue call tags.

Call CHAUVET® and request a Return Merchandise Authorization (RMA) number before shipping the fixture. Be prepared to provide the model number, serial number, and a brief description of the cause for the return.

The user must clearly label the package with a Return Merchandise Authorization (RMA) number. CHAUVET® will refuse any product returned without an RMA number.



**DO NOT write the RMA number directly on the box. Instead, write it on a properly affixed label.**

Once you have received the RMA number, please include the following information on a piece of paper inside the box:

- Your name
- Your address
- Your phone number
- The RMA number
- A brief description of the problem

Be sure to pack the fixture properly. Any shipping damage resulting from inadequate packaging will be the customer's responsibility. As a suggestion, proper UPS packing or double-boxing is always a safe method to use.



**CHAUVET® reserves the right to use its own discretion to repair or replace returned product(s).**

---

## Claims

The carrier is responsible for any damage incurred during shipping to this product or any part that shipped with it. Therefore, if the received merchandise appears to have damages caused during shipping, the customer must submit the damage report and any related claims with the carrier, not CHAUVET®. The customer must submit the report upon reception of the damaged merchandise. Failure to do so in a timely manner may invalidate the customer's claim with the carrier.

For other issues such as missing components or parts, damage not related to shipping, or concealed damage, the customer must make claims to CHAUVET® within seven (7) days of receiving the merchandise.

## Contact Information

### World Headquarters

CHAUVET®

#### General Information

Address: 5200 NW 108th Avenue  
Sunrise, FL 33351  
Voice: (954) 929-1115  
Fax: (954) 929-5560  
Toll free: (800) 762-1084

#### Technical Support

Voice: (954) 929-1115 (Press 4)  
Fax: (954) 756-8015  
Email: tech@chauvetlighting.com

#### World Wide Web

[www.chauvetlighting.com](http://www.chauvetlighting.com)

### United Kingdom & Ireland

CHAUVET® Europe Ltd.

#### General Information

Address: Unit 1C  
Brookhill Road Industrial Estate  
Pinxton, Nottingham, UK  
NG16 6NT  
Voice: +44 (0)1773 511115  
Fax: +44 (0)1773 511110

#### Technical Support

Email: [uktech@chauvetlighting.com](mailto:uktech@chauvetlighting.com)

#### World Wide Web

[www.chauvetlighting.co.uk](http://www.chauvetlighting.co.uk)

## 6. TECHNICAL SPECIFICATIONS

### *Dimensions and Weight*

Length	Width	Height	Weight
43.5 in (1,062 mm)	3 in (88 mm)	6 in (90 mm)	4.4 lbs (2 kg)

**Note:** Dimensions in inches rounded to the nearest decimal digit.

### *Power*

Power Supply Type	Range	Voltage Selection
Switching (internal)	100~240 V, 50/60 Hz	Auto-ranging
Parameter	120 V, 60 Hz	230 V, 50 Hz
Consumption	63 W (0.53 A)	66 W (0.29 A)
Power I/O	Input	Output
Connectors	IEC	Edison/IEC
Cord plug	Edison	N/A

### *Light Source*

Type	Power	Lifespan
LED	¼ W	50,000 hours
Color	Quantity	Current
Red	128	20 mA
Green	96	20 mA
Blue	96	20 mA

### *Photo Optic*

Parameter	Narrow Lenses
Illuminance @ 1 m	2,178 lux
Illuminance @ 2 m	1,043 lux
Beam angle	13°
Field angle	21°

### *Thermal*

Maximum External Temp.	Cooling System
104° F (40° C)	Convection

### *DMX*

I/O Connectors	Connector Type	Channel Range
3-pin XLR	Sockets	2, 3, 4, 7, 14, 26

### *Ordering*

Item Name	Ordering Code	Item Code
COLORrail™ IRC	COLORRAILIRC	03030378